



4.7 Ecology
Foundation and Higher

Name: _____

Class: _____

Date: _____

Time: **410 minutes**

Marks: **408 marks**

Comments:

Q1.

Students used quadrats to estimate the population of dandelion plants on a field.

- (a) Describe how quadrats should be used to estimate the number of dandelion plants in a field.

(4)

- (b) The field measured 40 m by 145 m.

The students used 0.25 m² quadrats.

The students found a mean of 0.42 dandelions per quadrat.

Estimate the population of dandelions on the field.

Estimated population of dandelions = _____

(2)

- (c) In one area of the field there is a lot of grass growing in the same area as dandelions.

Suggest why the dandelions may **not** grow well in this area.

(4)
(Total 10 marks)

Q2.

The graph shows changes in temperature and in carbon dioxide concentration in the earth's atmosphere between 1860 and 1990.

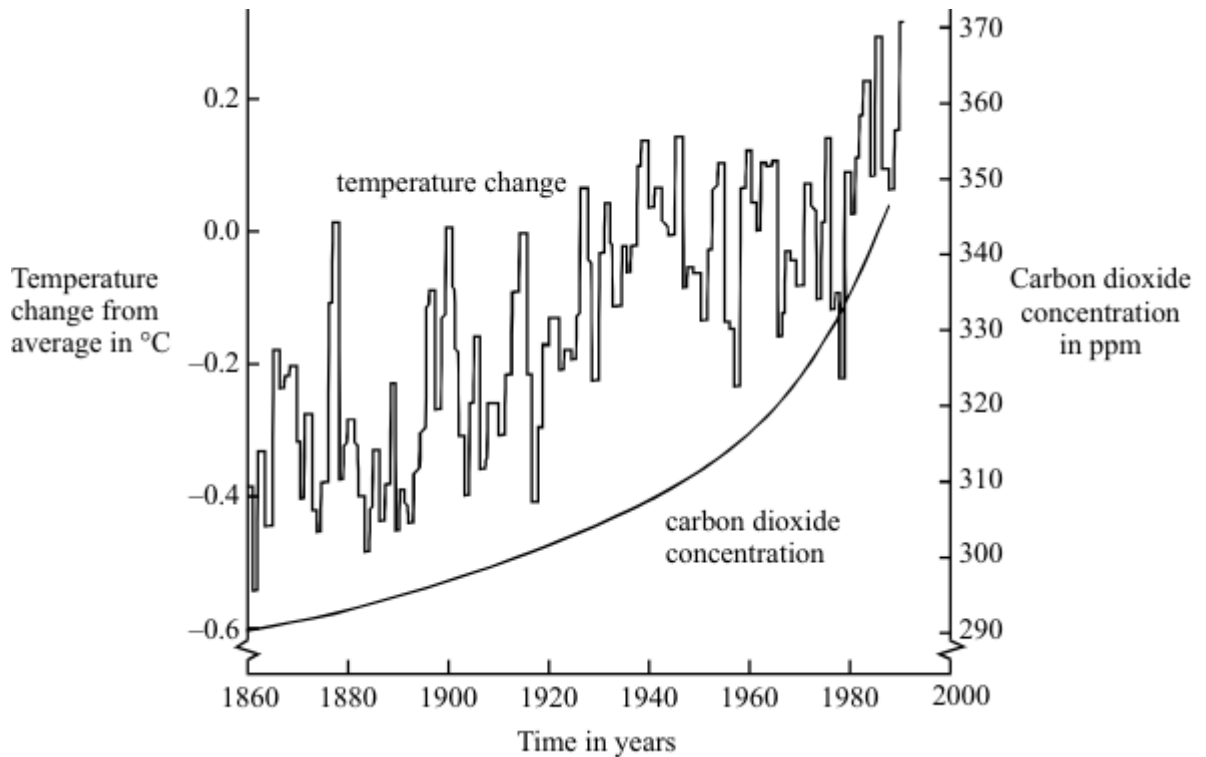

- (a) Give **two** human activities which may have helped to increase the concentration of carbon dioxide in the atmosphere.

1 _____

2 _____

(2)

- (b) (i) Describe the changes in temperature shown by the graph between 1860 and 1990.

(2)

- (ii) Do the data in the graph prove that increased carbon dioxide concentrations in the atmosphere caused the changes in temperature you described in part (b)(i)?
Give a reason for your answer.

(1)

- (c) Describe **one** way in which a change in temperature such as that shown in the graph might affect the environment.

(1)

(Total 6 marks)

Q3.

- (a) The diagram shows a cereal crop.

Complete spaces (i) and (ii).

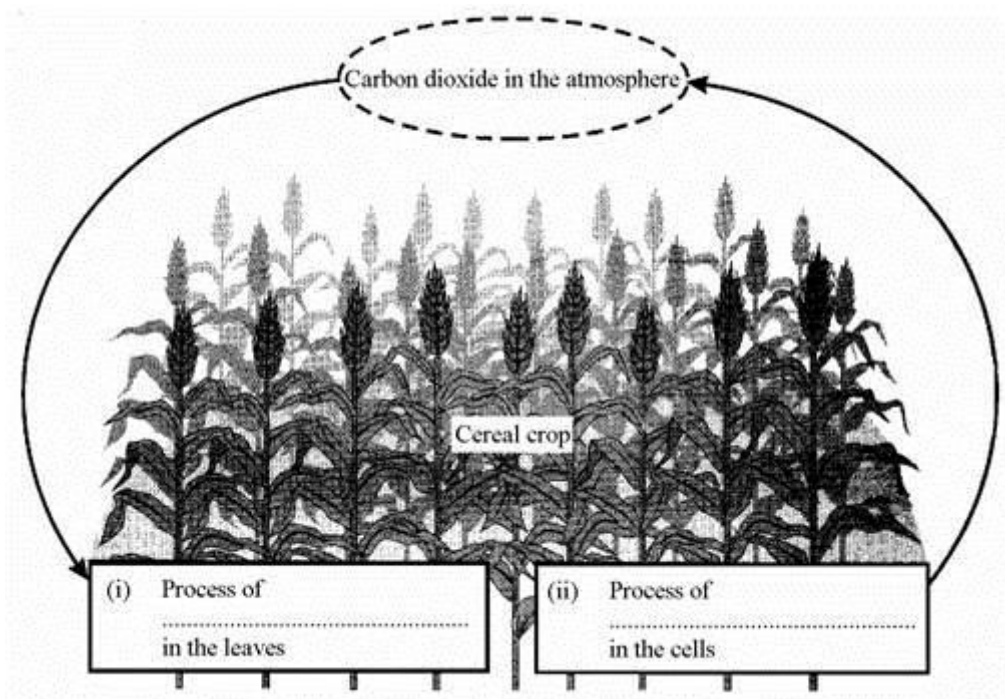

(2)

- (iii) What sort of weather may cause the cereal crop to wilt?

(1)

- (b) Describe the process of transpiration in plants.

Q4.

Tropical rainforests are being cut down to provide hardwood for furniture and to make way for roads and for agriculture. In the 1990s they were being destroyed at a rate of 15 hectares per minute.

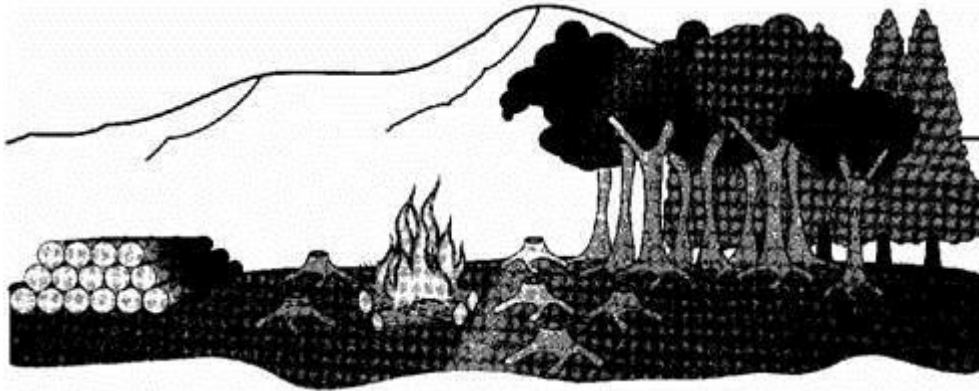

(a) Calculate the number of hectares destroyed in **one** day.

_____ hectares

(1)

(b) Soil erosion can be increased by deforestation. Explain how.

(2)

(c) (i) The gas carbon dioxide can contribute to the greenhouse effect. Explain how deforestation over a wide area can contribute to the greenhouse effect.

(3)

(ii) One result of the increased greenhouse effect is global warming. Describe **two** possible effects of global warming on the world.

(2)

- (iii) It is possible that planting new forests could stop global warming. Explain why this could happen.

(2)
(Total 10 marks)

Q5.

Dandelions have become adapted to live in lawns and grass areas where animals graze. Goosegrass, however, has become adapted to live alongside hedgerows and cannot survive being mown.

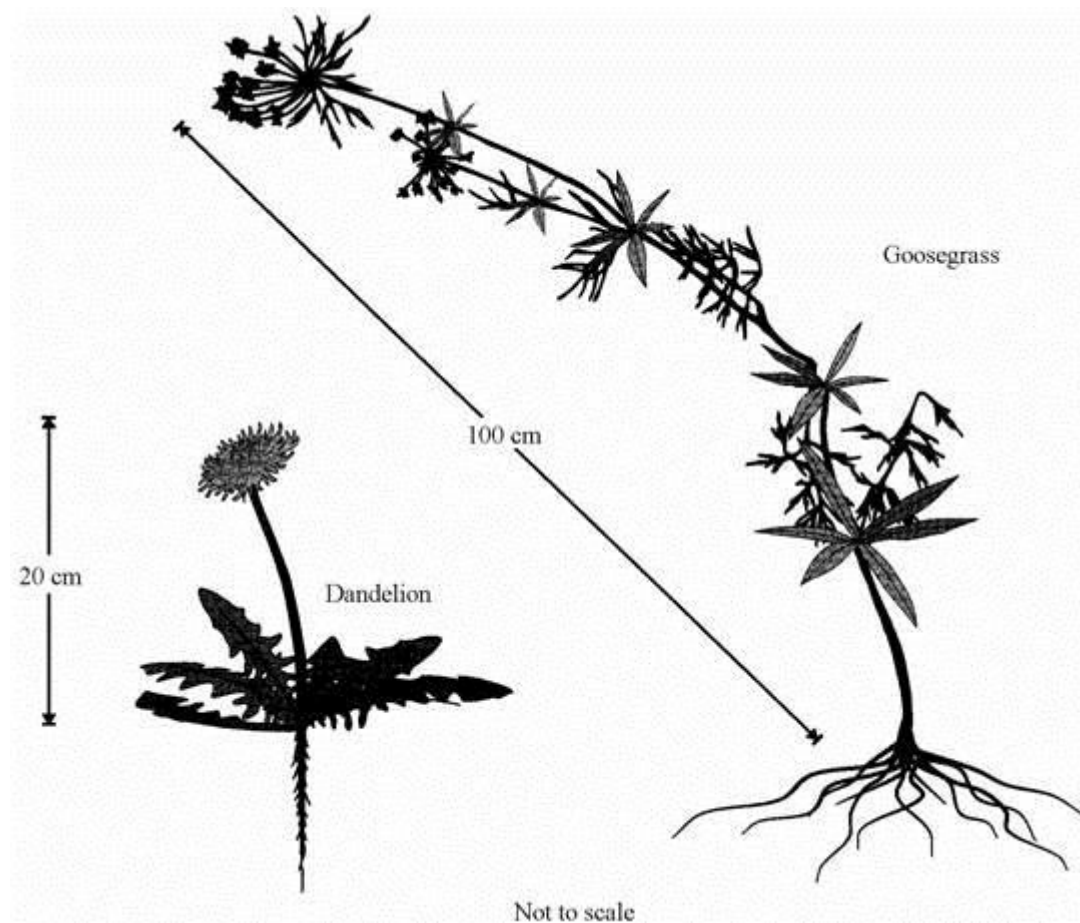

- (a) Use the information in the drawings to suggest **one** advantage of each of the following adaptations.

- (i) Dandelion leaves lie flat on the ground.

(1)

- (ii) A dandelion has a thick tapered root.

(1)

(iii) Goosegrass stems are long.

(1)

(iv) Goosegrass roots are thin and very long.

(1)

(b) Dandelions and goosegrass are different species of plants.

(i) What name is given to the unit of inheritance which controls one particular characteristic of a plant or animal?

(1)

(ii) Why would you be unlikely to succeed if you tried to breed a new species of plant by crossing a dandelion with goosegrass?

(1)

(c) Animals as well as plants have become adapted to live in different environments.

State **one** way a polar bear has become adapted to living in the Arctic, and the reason for the adaptation.

(2)

(Total 8 marks)

Q6.

Recently the concentration of carbon dioxide in the Earth's atmosphere has increased slightly. This may be linked to an increase in the 'greenhouse effect'.

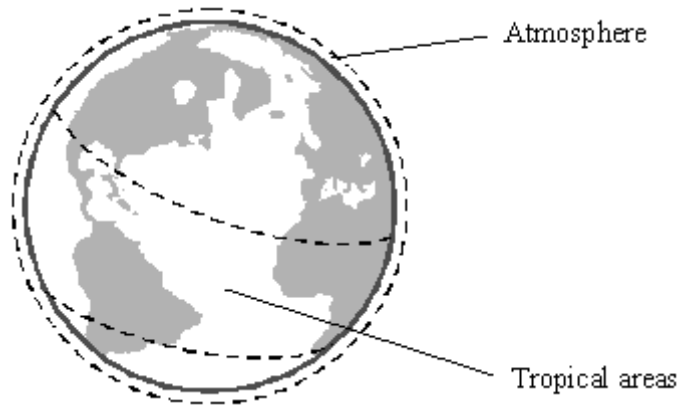

- (a) The human population has grown rapidly. This has caused an increase in the amount of land used for agriculture, especially in tropical areas. This has helped to increase the carbon dioxide in the atmosphere.

Give **two** reasons for this.

1. _____

2. _____

(2)

- (b) The increased 'greenhouse effect' has caused an increase in the Earth's average temperature.

Give **two** possible environmental effects of this increased average temperature.

1. _____

2. _____

(2)

- (c) Name another gas, produced by cattle and rice fields, that also helps cause the 'greenhouse effect'.

(1)

(Total 5 marks)

Q7.

Improving the quality of life for everyone without damaging the planet for the future is known as sustainable development.

One problem is the rapid growth in the Earth's population of humans during the last 500 years. This is shown by the graph.

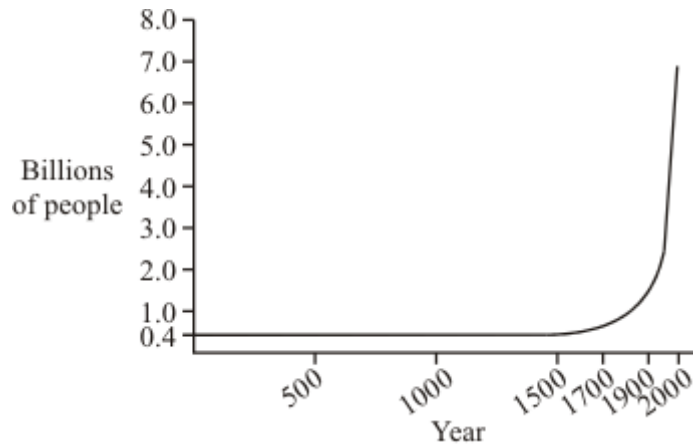

- (a) When the Earth's population was much smaller, the effects of human activities on forests were usually small and local. In the past 500 years there has been large-scale deforestation in some areas. Give **two** reasons for this.

1. _____
2. _____

(2)

- (b) Look at the bar chart. It shows the average amount of energy used by each person in one year in the USA, Japan and Bangladesh.

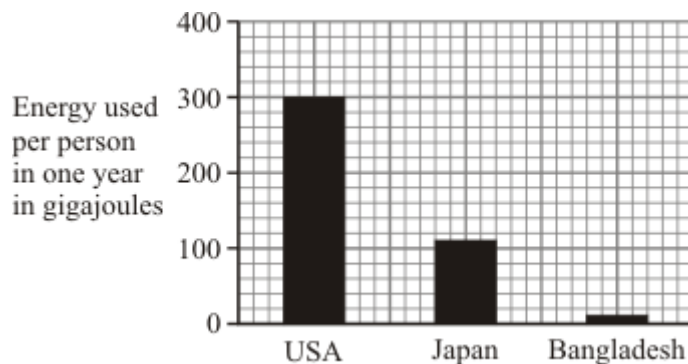

- (i) Suggest **one** reason why so much more energy is used per person in the USA than in Bangladesh.

(1)

- (ii) Using a lot of resources for energy harms the Earth. Explain why.

(2)

- (c) As we are using more resources, waste management is becoming more important. In the UK much of the solid waste is still being dumped in landfill sites. In 1996, the UK government introduced a landfill tax because landfill sites were being used up.

However, the year after the landfill tax was introduced it was estimated that 18 million tonnes of landfill waste was not reported. The government was trying to encourage other forms of waste management, such as:

- reduce waste
- reuse waste
- recycle waste

(i) Explain the main problem caused by the landfill tax.

(2)

(ii) Describe **one** example of how each of the different forms of waste management can be put into practice.

Reduce waste _____

Reduce waste _____

Reduce waste _____

(3)

(Total 10 marks)

Q8.

Coal is used in many power stations.

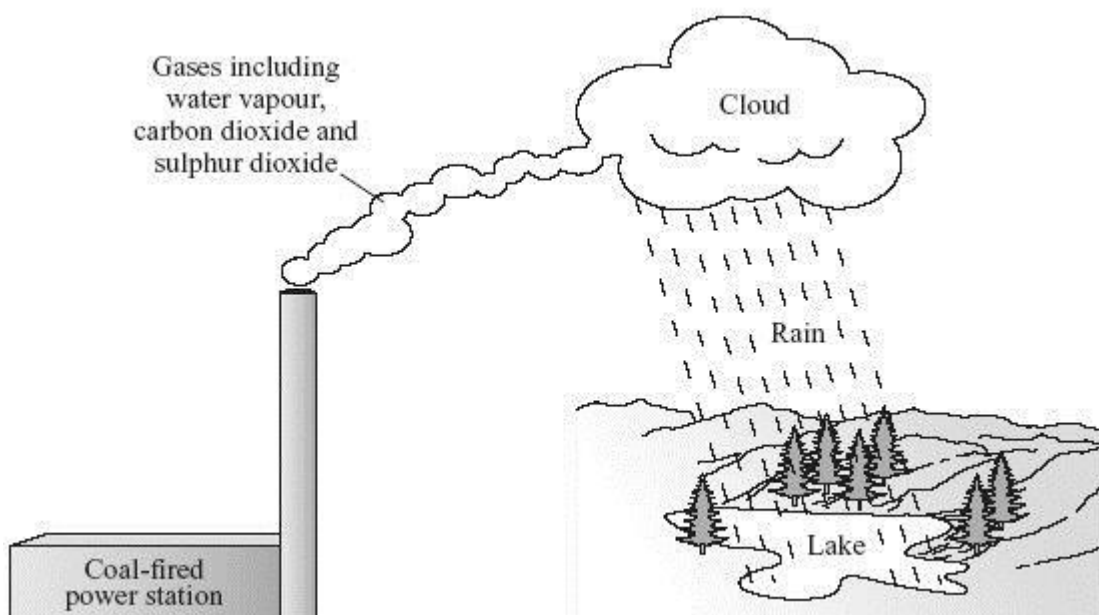

To gain full marks in this question you should write your ideas in good English. Put them into a sensible order and use the correct scientific words.

Use information from the diagram to describe, in as much detail as you can, how using coal in power stations can damage the environment.

(Total 4 marks)

Q9.

The drawings show an arctic fox and a fennec fox.

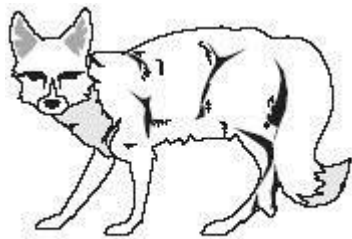

Arctic fox



Fennec fox

(a) The arctic fox lives in cold, snowy conditions.

Explain how each of the following helps the arctic fox to survive in these conditions.

1 Long, thick fur

2 A white coat

(2)

(b) The fennec fox lives in hot deserts.

Explain how each of the following helps it to survive in hot conditions.

1 Very large ear flaps

2 Hairs on the soles of its feet

(2)
(Total 4 marks)

Q10.

In a sewage works, human waste is broken down by microorganisms. Air is blown through this sewage.

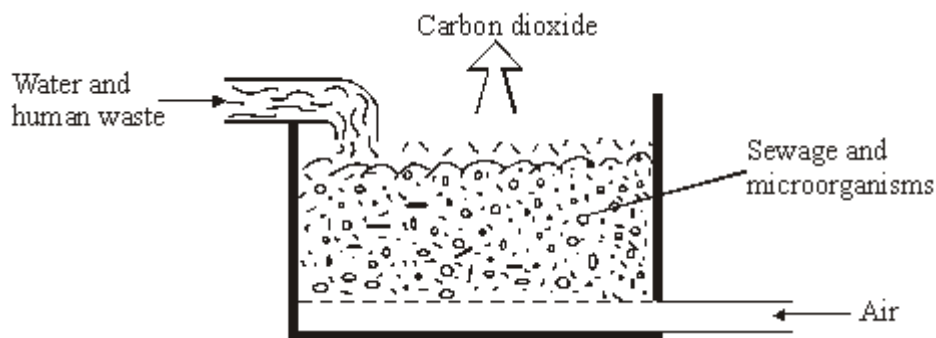

To gain full marks in this question you should write your ideas in good English. Put them into a sensible order and use the correct scientific words.

Carbon dioxide is formed from the mixture of sewage, microorganisms and air. Explain how.

(3)
(Total 3 marks)

Q11.

The concentration of carbon dioxide in the Earth's atmosphere is rising.

The rise in carbon dioxide concentration may cause more of the Earth's surface to become desert.

The drawing shows a plant that is adapted to life in a hot, dry desert.

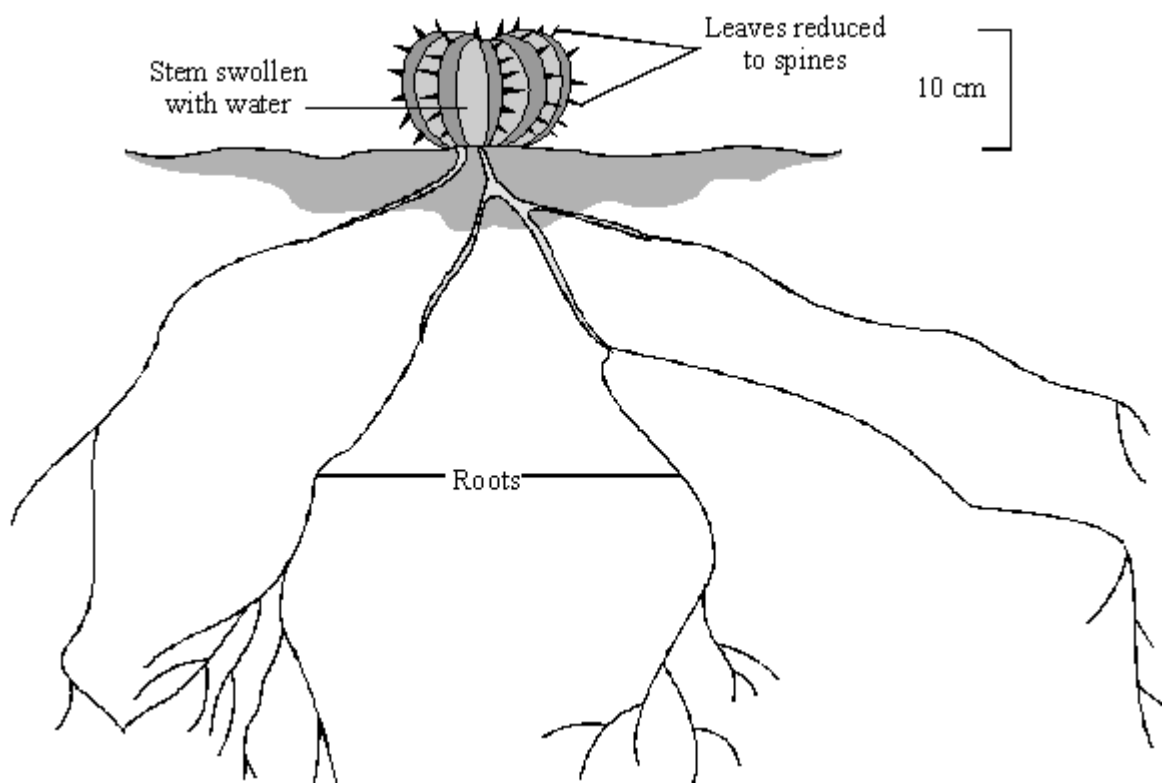

Suggest **two** ways in which the structure of the plant helps it to survive in a hot, dry desert.

1. _____

2. _____

(Total 2 marks)

Q12.

Coastal grazing marshes provide grazing for cattle and sheep. They also support huge numbers of birds and a wide range of water plant and animal communities. Some of these communities include nationally rare species.

There has been a dramatic reduction in the extent of the grazing marshes in the estuary of the river Thames in recent years. These grazing marshes are downstream from the capital city, London.

The table below shows what some of the grazing marshes have been converted into.

CONVERTED TO	MEAN ANNUAL RATE OF CONVERSION TO OTHER LAND-USED (Hectares/Year)			
	1935-68	1968-72	1972-81	1981-89

Roads and buildings	83	186	142	45
Formal open spaces (parks)	11	30	12	27
Arable (crop-growing)	49	188	90	102
Open water	9	9	7	4
Woodland	3	1	3	2

(a) Explain, as fully as you can, why you think it has been necessary to convert these marshes to other uses.

(3)

(b) Explain, as fully as you can, the possible further effects that these changes in land-use might have on the environment and on the organisms which live in the environment.

(4)

(Total 7 marks)

Q13.

The drawings show changes to a farm between 1953 and 1983.

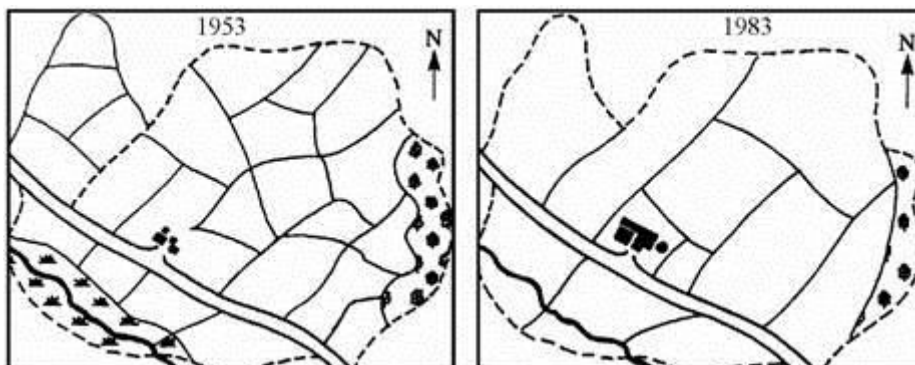

Key	
Hedges	—
Boundary	- - - - -
River	⌞
Buildings	■ ■
Trees	⊕ ⊕
Marsh	⊞ ⊞ ⊞

The fields on the farm are separated by hedges.

- (i) Give **two** major changes which were made to the land on this farm between 1953 and 1983.

1. _____

2. _____

(2)

- (ii) How would these changes affect the number of wild animals which live on the farmland?

Explain your answer.

(2)

(Total 4 marks)

Q14.

The drawing shows an industrial estate and the neighbouring area.

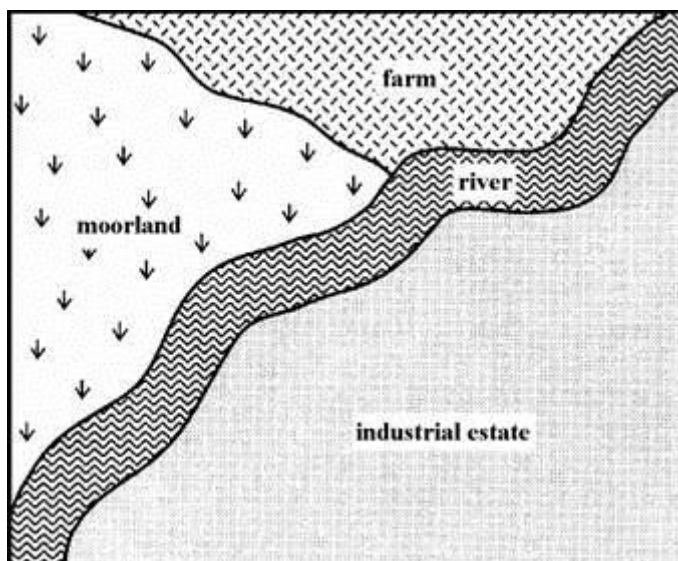

- (a) Use words from the list to complete the sentences about effects on the

environment.

fertilisers

fuels

nitrogen

oxygen

pesticides

smoke

sulphur dioxide

Factories in the industrial estate burn _____ . This pollutes the air with _____ and _____ .

The farm may pollute the river with chemicals such as _____ and _____ .

(5)

(b) Describe how sulphur dioxide may damage the environment.

(2)

(Total 7 marks)

Q15.

The gemsbok is a large herbivore that lives in herds in desert areas of South Africa. Gemsboks feed on plants that are adapted to living in dry conditions. There are not many rivers, lakes or ponds that can provide drinking water for the animals. The desert areas are hot during the day but cool at night. As the air cools at night it becomes moist, and the plants absorb the moisture.



- (a) A few lions live in the desert areas. They hunt and feed on the gemsboks.

Use information from the drawing of the gemsbok to suggest **two** ways in which it could avoid being killed by lions.

1. _____

2. _____

(2)

- (b) The graphs show the water content of the desert grass and the times of day that the gemsboks feed.

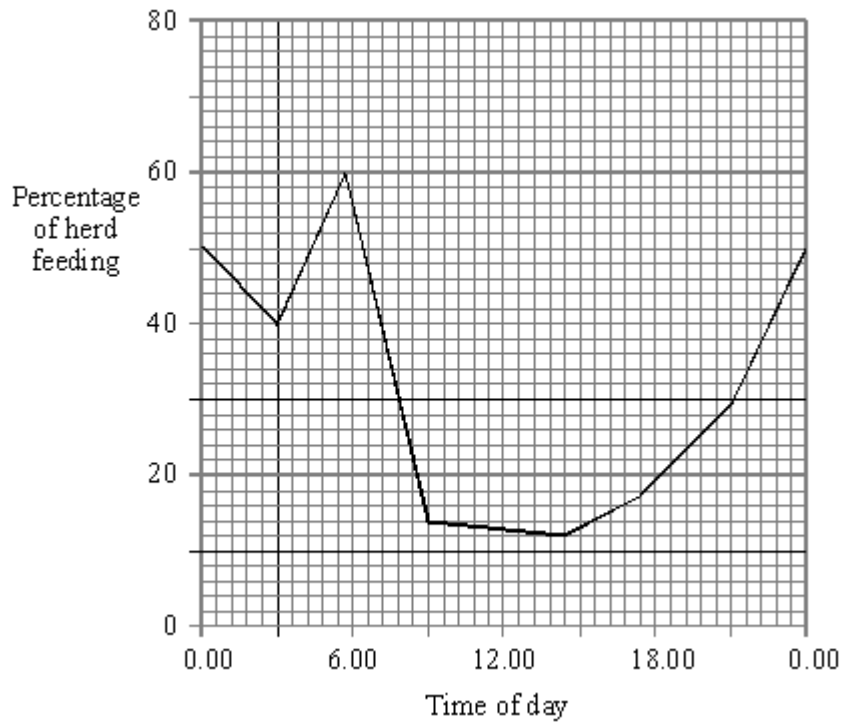
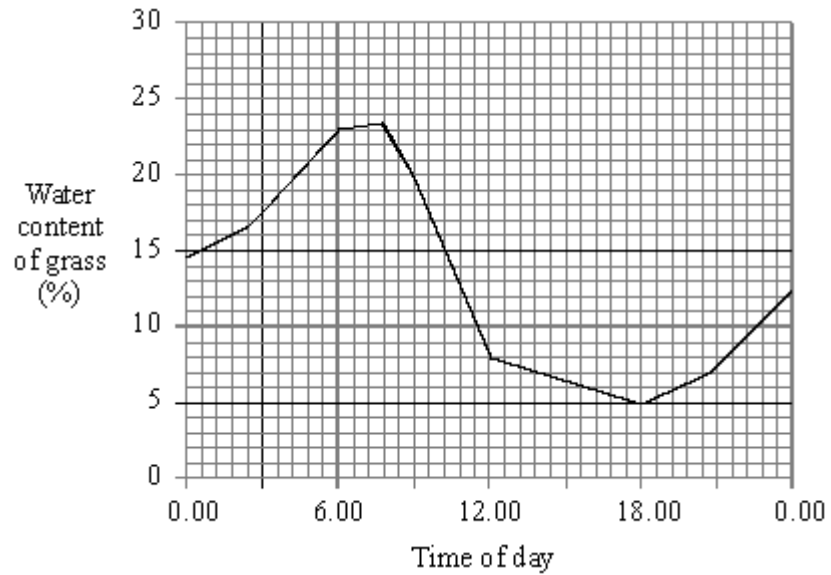

(i) Describe how the water content of the grass changes during the day.

(1)

(ii) Suggest why the water content of the grass changes.

(1)

(c) (i) Between which times of day are more than 25% of the herd feeding?

_____ and _____

(1)

(ii) Suggest an advantage to the gemsbok of feeding mainly at these times.

(2)

(Total 7 marks)

Q16.

The chart is about some of the animals which live in a forest. It shows the time of day when they search for food.

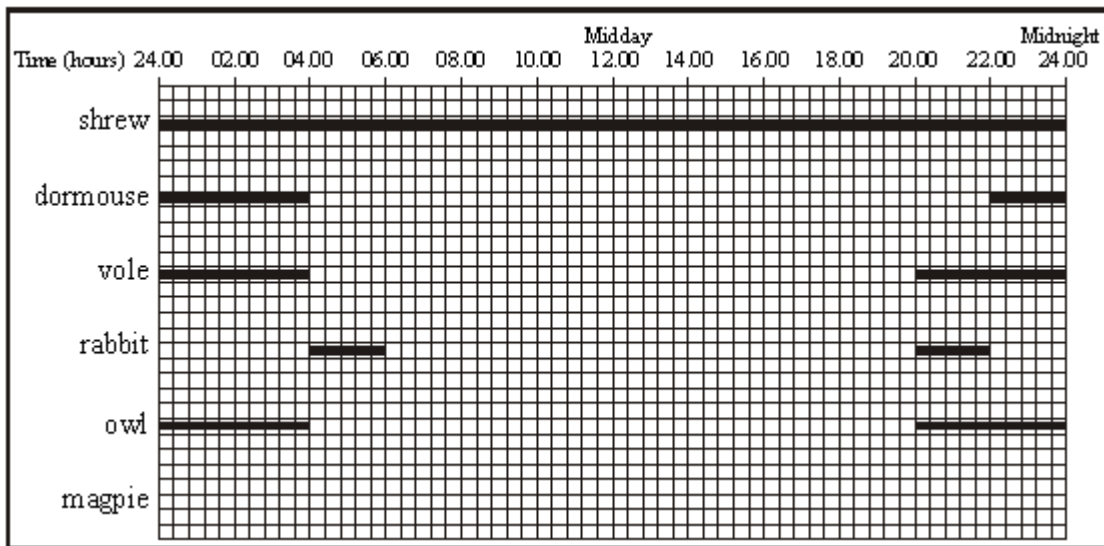

(a) The dormouse searches for food from 22.00 until 04.00 hours.

When does the owl search for food? _____

(1)

(b) The magpie searches for food from 06.00 until 20.00 hours.

Add this information to the diagram.

(1)

(c) The vole searches for food only between 20.00 and 04.00 hours.

Suggest an explanation for this.

Q17.

The table shows the results of a ten-year study of the owls and voles in a forest.

YEAR	NUMBER OF VOLES (TO THE NEAREST THOUSAND)	NUMBER OF OWLS
1	15 000	8
2	12 000	9
3	15 000	7
4	23 000	9
5	40 000	14
6	2 000	28
7	9 000	8
8	19 000	9
9	10 000	14
10	8 000	16

The data for years 1 - 7 have been plotted on the grid below.

(a) Complete the graph by plotting the data for years 8 - 10.

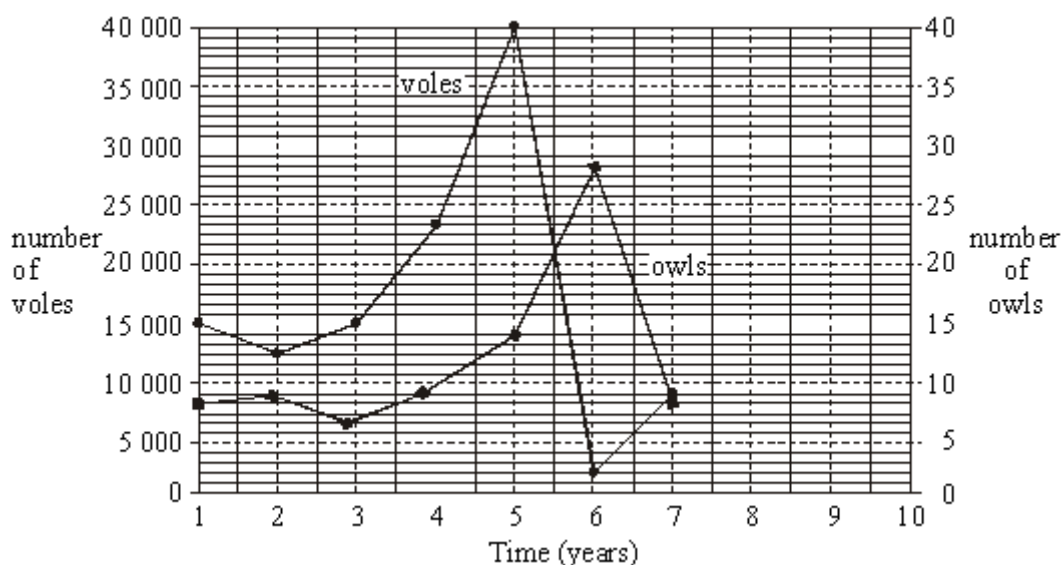

(2)

(b) (i) What is the main factor which limits the size of the owl population?

(1)

(ii) Suggest **two** reasons other than owl predation, for the large fall in the numbers of voles between years 5 and 6.

1. _____

2. _____

(2)

(Total 5 marks)

Q18.

The diagram below shows the mass of carbon involved each year in some of the processes in the carbon cycle.

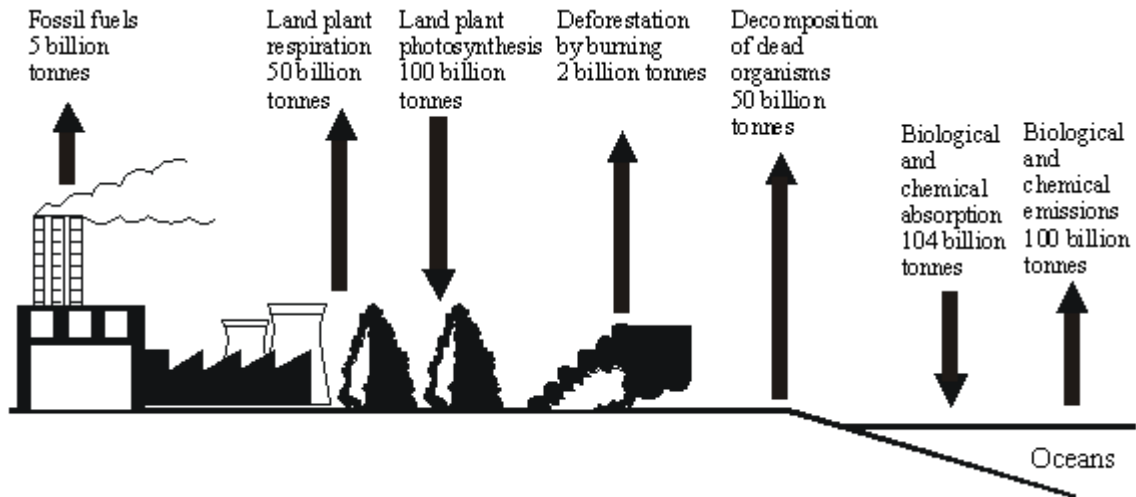

(a) Complete the equation for plant respiration.

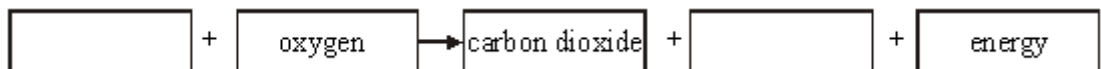

(2)

(b) (i) Calculate the mass of carbon removed from the atmosphere each year. (Show your working.)

Answer _____ billion tonnes

(1)

(ii) Calculate the percentage of this total which is removed by the photosynthesis of land plants. (Show your working.)

Answer _____ %

(2)

(iii) Calculate the net gain of carbon by the atmosphere in one year. (Show your working.)

Answer _____ billion tonnes

(2)

(Total 7 marks)

Q19.

Squirrels live mainly in woodland. There are two types of woodland in Great Britain: coniferous woodland containing trees such as Scots pine and Norway spruce, and broad-leaved woodland containing trees such as Hazel, Beech, Oak, Sycamore and Sweet chestnut.

The red squirrel is a native species, the grey squirrel was introduced at the beginning of this century. Since the introduction of the grey squirrel, the red squirrel has largely disappeared from broad-leaved forests in England.







- (a) Suggest **two** factors which might have caused the fall in the population of red squirrels.

1. _____

2. _____

(2)

- (b) The drawing gives information about the two types of squirrel.

RED ← HOW THEY DIFFER → GREY						
Weight: ¾ lb	Weight: 1½ lb					
Appearance: tufted ears and chocolate coat in winter; chestnut in summer.	Appearance: ears not tufted, silver-grey coat in winter, yellow-brown in summer					
Habitat: favours large coniferous forest.	Habitat: favours broadleaved woodland and can colonise hedgerows.					
The red has a shy, retiring nature and spends 70% of time in the forest canopy.	A natural showman and acrobat, the grey spends only 14% of time in the canopy.					
FOODS THE REDS LIKE... AND THOSE THEY DON'T						
Scots pine cone	Hazel nuts	Norway spruce cone	Beech mast	(Oak) acorns	Sycamore	Sweet chestnut
						

Up to six times as many grey squirrels as red can populate broadleaved woodlands, while red squirrels can match the density of greys only in coniferous forests

Using **only** information given above, suggest **two** reasons why the population of grey squirrels has risen whereas the population of red squirrels has fallen.

1. _____

2.

(2)
(Total 4 marks)

Q20.

The drawings show a humming bird and a sun bird feeding.

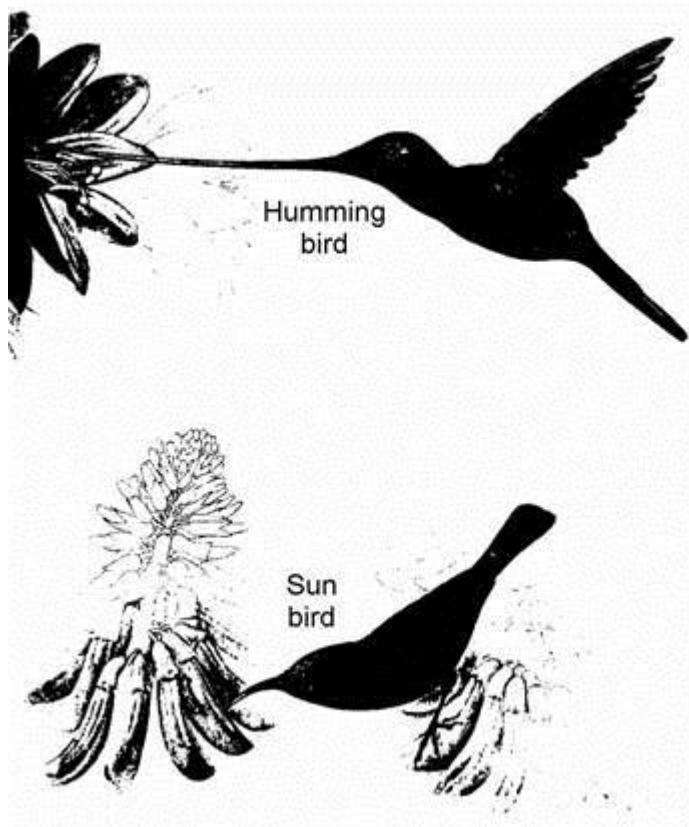

Both of these birds feed on nectar which is a sugary liquid found inside flowers.

Use the information from the drawings to answer the following questions.

- (a) Describe, as fully as you can, how the humming bird is adapted for feeding on nectar.

(2)

- (b) The sun bird has a different method of obtaining nectar.

Describe, as fully as you can, how the sun bird is adapted for feeding on nectar.

(2)
(Total 4 marks)

Q21.

Moose are animals that eat grass.

Figure 1 shows a moose.

Figure 1



© Wildnerdpix/iStock/Thinkstock

Figure 2 shows a food chain.

Figure 2

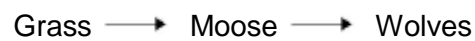

(a) Name the secondary consumer shown in **Figure 2**.

(1)

(b) **Figure 3** shows how the moose population and wolf population have changed in one area.

This is a predator-prey cycle.

Figure 3

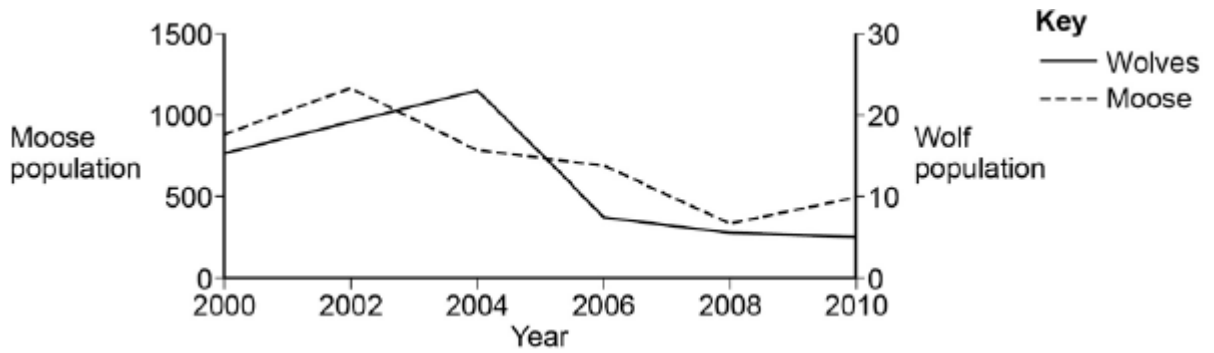

In 2004 the line on **Figure 3** for wolves is above the line for moose.

How does **Figure 3** show that there are more moose than wolves in 2004?

(1)

(c) Suggest why the moose population decreased between 2002 and 2004.

Use information from **Figure 3**.

(1)

(d) The number of wolves is one biotic factor that could affect the size of the moose population.

Give **two** other biotic factors that could affect the size of the moose population.

1. _____

2. _____

(2)

(e) Moose have distinct characteristics such as antlers.

Describe how moose may have evolved to have large antlers.

(5)
(Total 10 marks)

Q22.

(a) Use the words in the box to fill in the gaps in the diagram. You may use each word once or not at all.

carbon	burning	decay	eaten
nitrogen	oxygen	pollution	respiration

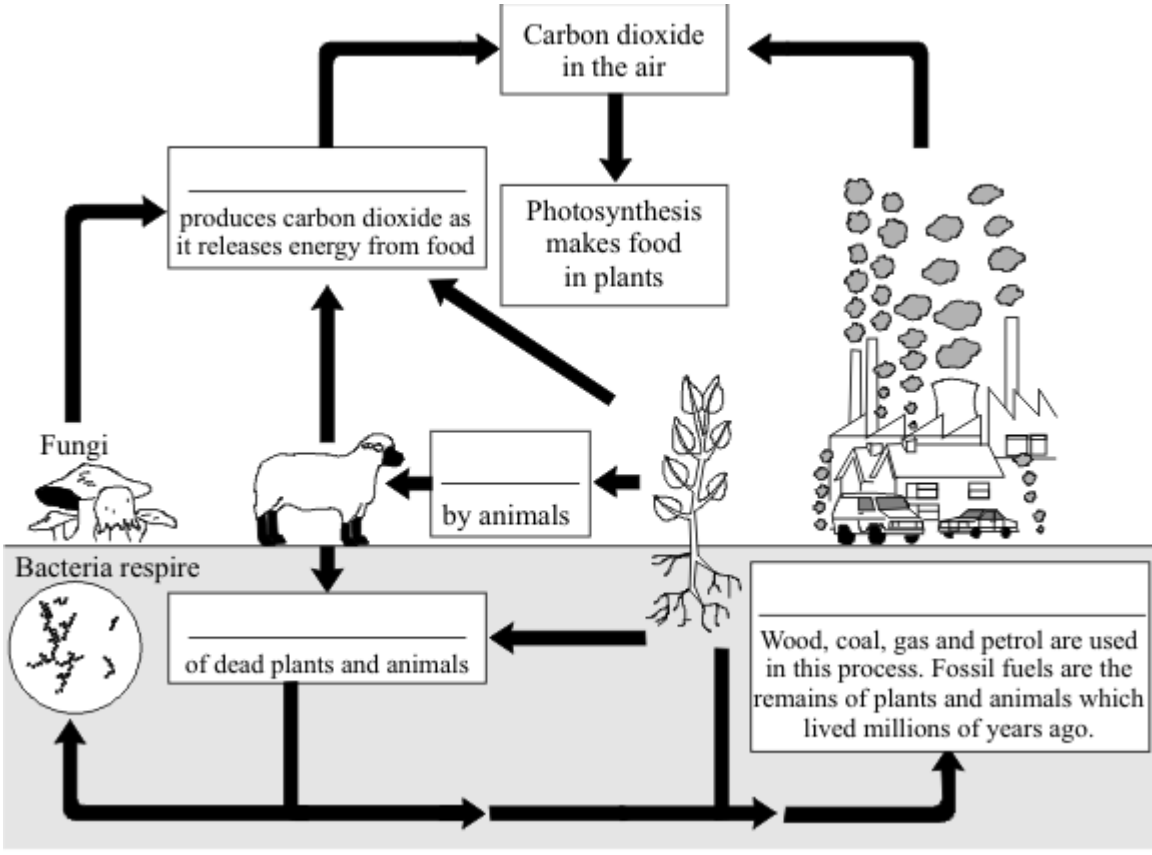

(4)

(b) (i) Why are fungi called decomposers?

(1)

(ii) Give **one** other type of decomposer.

(1)

(Total 6 marks)

Q23.

A population of rabbits lived on a small island. The graph shows their population over the last 50 years.

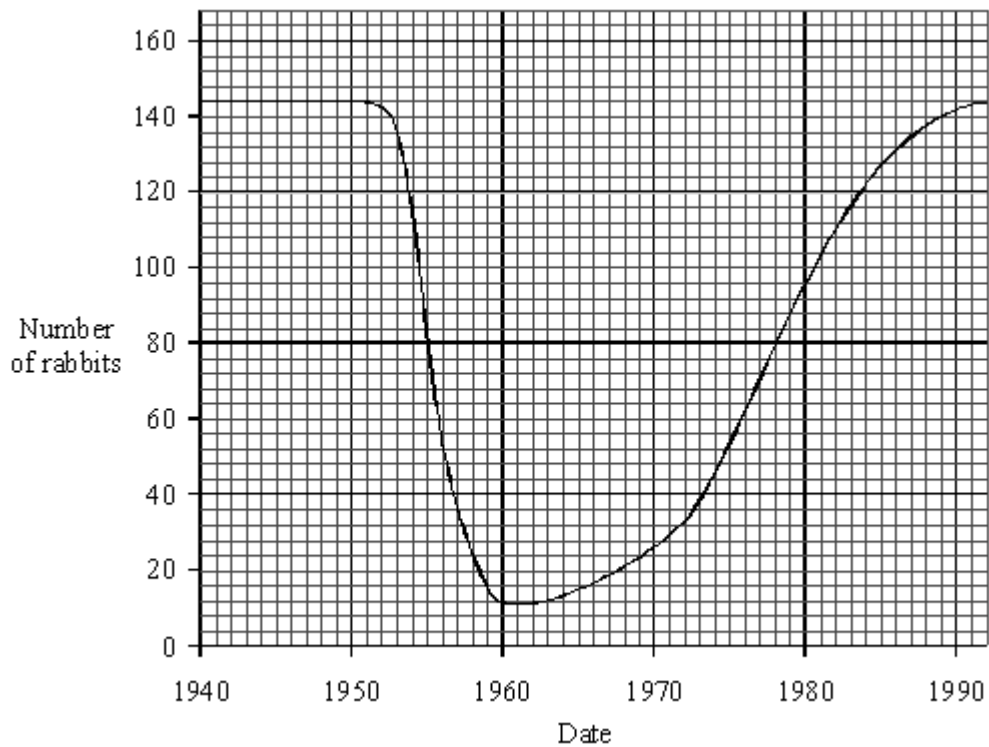
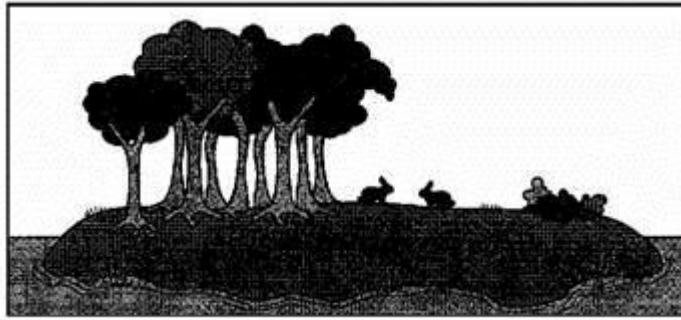

- (a) (i) How many rabbits were there on the island in 1950?

(1)

- (ii) Give **one** year when there were 88 rabbits on the island.

(1)

- (b) (i) Calculate the decrease in rabbit population between 1950 and 1960.

(1)

- (ii) Suggest a reason why the rabbit population fell in these years.

(1)

(c) The most rabbits on the island is always about 140. Suggest a reason for this.

(1)

(Total 5 marks)

Q24.

In December 1952, there was a thick fog in London. The graph shows changes in the amounts of sulphur dioxide and smoke in the air and the number of people dying during this period.

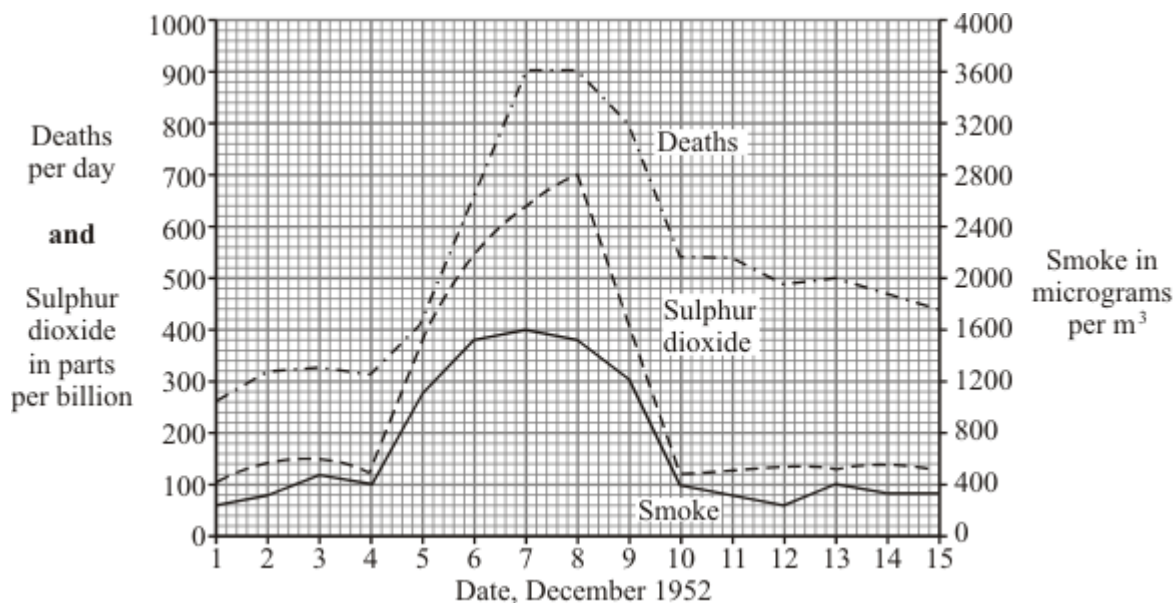

(a) Describe **one** human activity which releases sulphur dioxide into the air.

(1)

(b) Human deaths during this period were caused mainly by lung diseases.

(i) Why were the lungs particularly affected?

(1)

(ii) Give evidence from the graph which suggests that sulphur dioxide might have caused these deaths.

(1)

(iii) Does the graph prove that sulphur dioxide caused these deaths? Explain your answer.

(1)
(Total 4 marks)

Q25.

Deforestation affects the environment in many ways.

- (a) Deforestation increases the amount of carbon dioxide in the atmosphere.

Give **two** reasons why.

1. _____

2. _____

(2)

- (b) Deforestation also results in a loss of *biodiversity*.

- (i) What is meant by *biodiversity*?

(1)

- (ii) Give **one** reason why it is important to prevent organisms from becoming extinct.

(1)

(Total 4 marks)

Q26.

Red squirrels live in trees. They eat seeds from the cones of conifer trees. Squirrels store cones in 'larders' on the ground. These larders provide food through the winter. Each red squirrel makes and defends one larder.

Scientists monitor squirrel numbers to find the best habitats for the squirrel's survival. In one investigation, scientists estimated the numbers of squirrels in different types of woodland. Each woodland contains a different species of conifer tree.

Here is their method.

- Ten woods of each type of woodland were surveyed.
- In each wood scientists measured out two transects (strips), each 600 m long and 10 m wide.

- A scientist walked slowly down the centre of each transect, recording the number of squirrel ladders he could see.

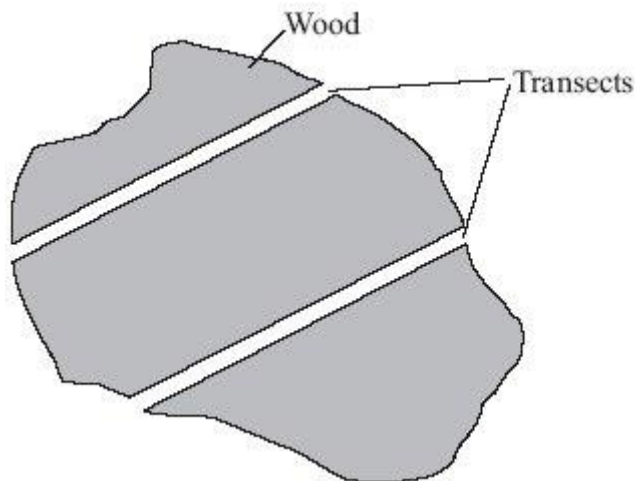

- (a) (i) How many transects all together did the scientists survey in each **type** of woodland?

Number of transects _____

(1)

- (ii) What was the total area surveyed in **one** wood?

Area _____ m²

(1)

- (b) Name **one** variable that was controlled in this investigation.

(1)

- (c) (i) The scientists recorded the number of ladders instead of the number of squirrels they saw.

Explain how this could have increased the accuracy of the investigation.

(1)

- (ii) This method of counting the number of ladders could have led to an inaccurate estimate of the number of squirrels.

Explain how.

(2)

(d) The results of the investigation are shown in the graph.

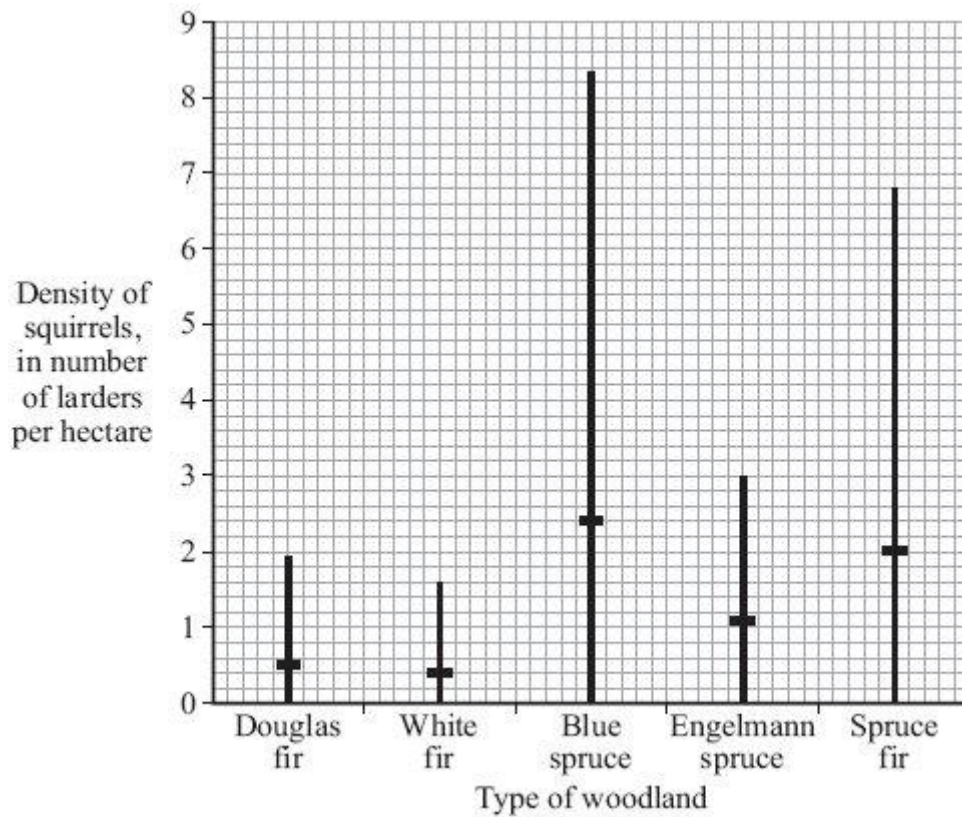

The horizontal mark on each bar represents the mean number of larders per hectare of woodland.

The range of the number of larders observed for Douglas fir woodland was 0 to 1.9 per hectare.

(i) What was the range of the number of larders per hectare in the Spruce fir woodland?

(1)

(ii) The highest mean number of larders per hectare was found in Blue spruce woodland.

Suggest **one** explanation for this.

(1)

(Total 8 marks)

Q27.

The drawing shows a bean caper plant.

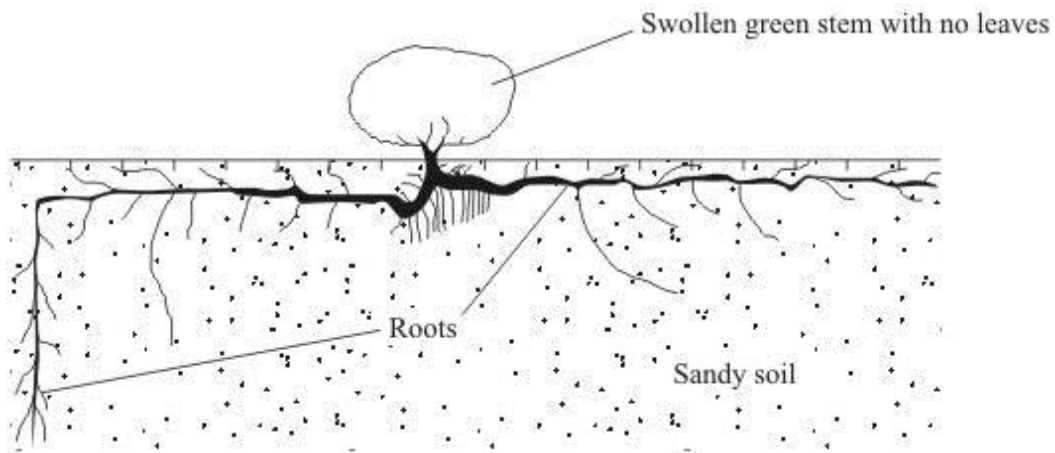

The bean caper plant lives in hot desert conditions.

Explain two ways in which the bean caper is adapted for life in a hot desert.

Adaptation 1 _____

How this adaptation helps the bean caper to survive

Adaptation 2 _____

How this adaptation helps the bean caper to survive

(Total 4 marks)

Q28.

Organisms have adaptations that enable them to survive in extreme conditions.

(a) The photograph shows an arctic fox.



This fox lives in the arctic, where it is very cold.

Suggest **two** ways in which the arctic fox is adapted for life in very cold conditions. Explain how each adaptation helps the arctic fox to survive in very cold conditions.

Adaptation 1 _____

How this adaptation helps the arctic fox to survive in very cold conditions.

Adaptation 2 _____

How this adaptation helps the arctic fox to survive in very cold conditions.

(4)

(b) The photograph shows an antelope that lives in a sandy desert.



The antelope is prey to large cats such as cheetah.

Suggest **two** adaptations that help this antelope to avoid being killed by predators. Explain how each adaptation helps the antelope to avoid being killed by predators.

Adaptation 1 _____

How this adaptation helps the antelope to avoid being killed by predators.

Adaptation 2 _____

How this adaptation helps the antelope to avoid being killed by predators.

(4)
(Total 8 marks)

Q29.

The diagram shows the mass of carbon exchanged between carbon reservoirs and the atmosphere. The pie chart in the diagram shows the mass of carbon in three reservoirs: oceans, soils and fossil fuels. The figures are in billions of tonnes of carbon per year.

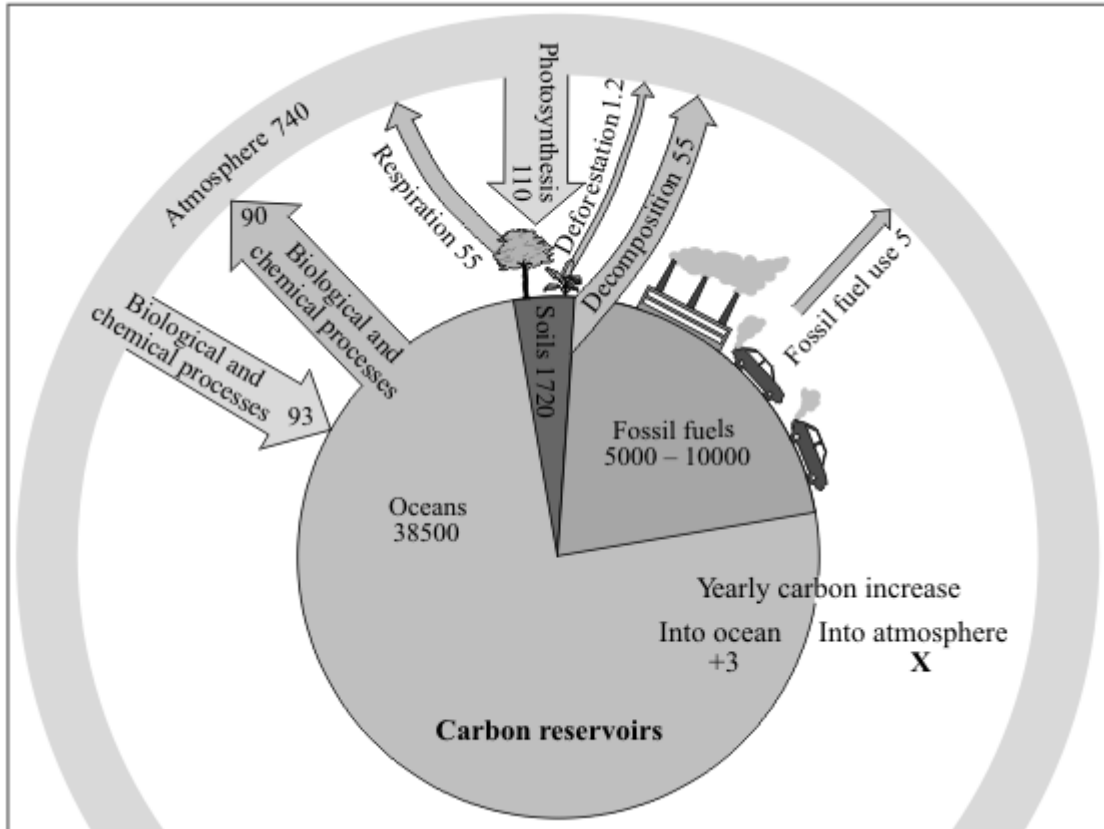

Reproduced by permission of Philip Allan Updates

- (a) Calculate **X** (the yearly carbon increase into the atmosphere).

Show all your working.

X = _____ billion tonnes of carbon

(2)

- (b) Give **one** reason why deforestation increases the carbon dioxide concentration of the atmosphere.

(1)

(Total 3 marks)

Q30.

Swallows and swifts migrate between Britain and South Africa every year.

- (a) **Photograph 1** shows a swallow.

Photograph 1



Swallows can fly very quickly.

Use information from the photograph to give **one** way in which the swallow is adapted for flying very quickly.

(1)

(b) **Photograph 2** shows swifts.

Photograph 2



Swallows and swifts both feed on flying insects.
They both spend the summer in Britain and then migrate to South Africa in the autumn.

Suggest **one** reason why swallows and swifts do not stay in Britain in the winter.

(1)

(c) The table gives data about swallows and swifts.

	Swallows	Swifts
Arrival date in Britain	April	Early May
Leaving date from Britain	October	Early August
Food	Flying insects	Flying insects
Height at which the birds feed	Near ground level	Up to 350m above ground level
Times at which birds feed	Mainly when it is light	Almost 24 hours per day

(i) There is very little competition between swallows and swifts for food.

Use information from the table to suggest **two** reasons for this.

1. _____

2. _____

(2)

(ii) Swallows and swifts do compete for some factors.

Suggest **one** of these factors.

(1)

(Total 5 marks)

Q31.

The diagram shows part of the carbon cycle.

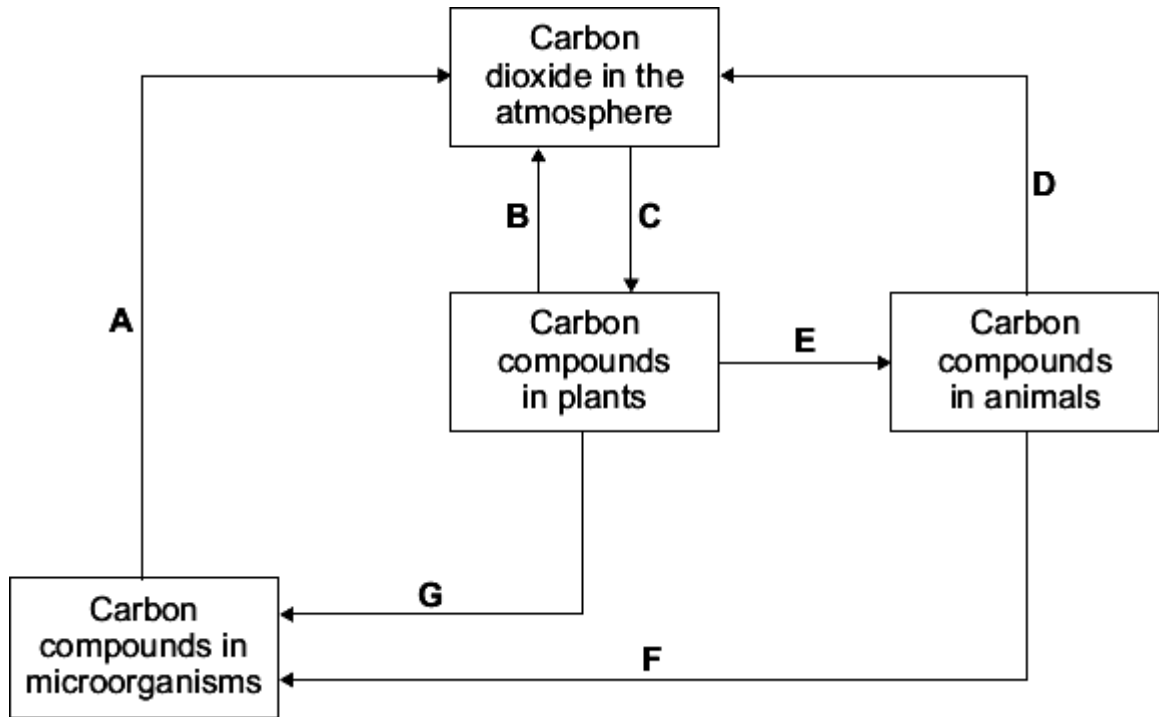

(a) Letter **A** represents respiration.

Which **two** other letters represent respiration?

and

(1)

(b) Other than carbon dioxide name **two** carbon compounds found in plants.

1. _____

2. _____

(2)

(c) Gardeners use compost heaps to decay dead plants. Decayed compost is then spread onto the soil in a garden.

Explain why gardeners spread decayed compost onto the soil.

(2)

(Total 5 marks)

Q32.

Some people are concerned about the distance that food is transported between the grower and the supermarket.

The bar chart shows the distances for some foods.

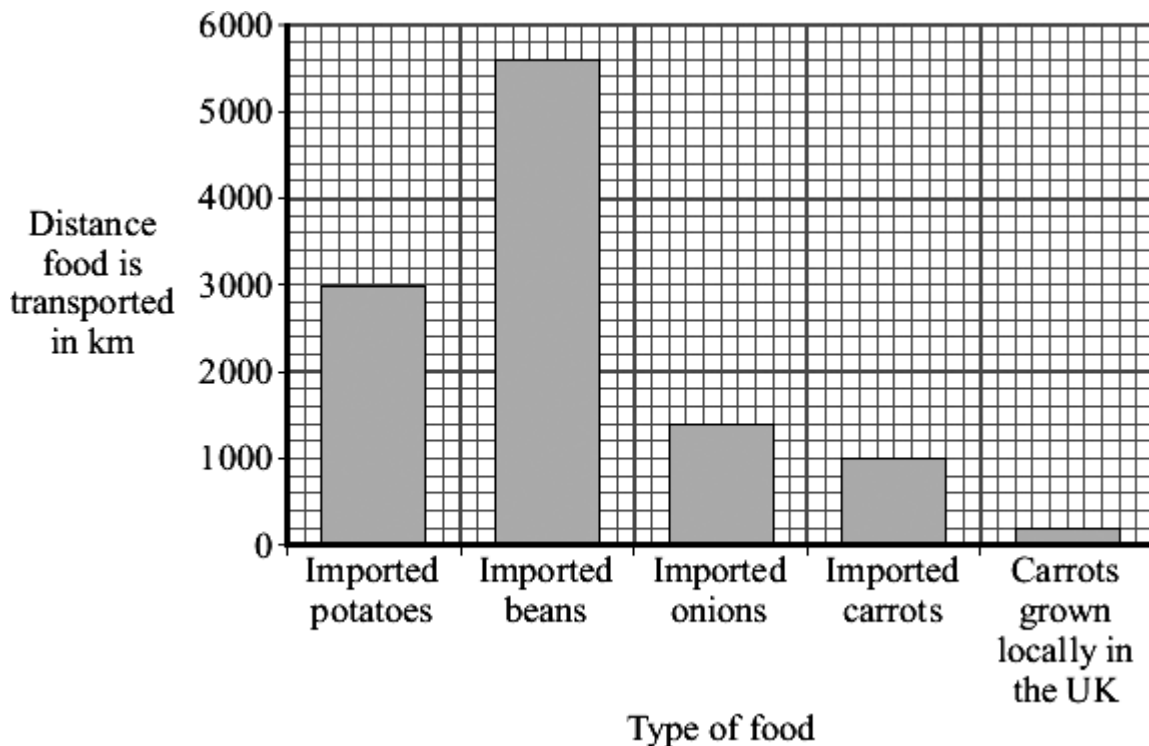

- (a) Both imported carrots and carrots grown locally in the UK can be bought in supermarkets all year round.

How many times further are imported carrots transported than carrots grown locally in the UK?

Show clearly how you work out your answer.

_____ times

(1)

- (b) Many of the beans sold in supermarkets in the UK are grown in Kenya, a tropical country in Africa.

Beans grow faster in Kenya than they do in the UK.

Suggest and explain **one** reason why.

Reason _____

Explanation _____

(2)

- (c) Many people believe that we should buy locally produced food instead of food imported from abroad.

Explain how this would help the environment.

(2)
(Total 5 marks)

Q33.

Seals are adapted for life in the sea.
Use information from the drawings to answer the questions.

This drawing shows seal **X**.

Seal X

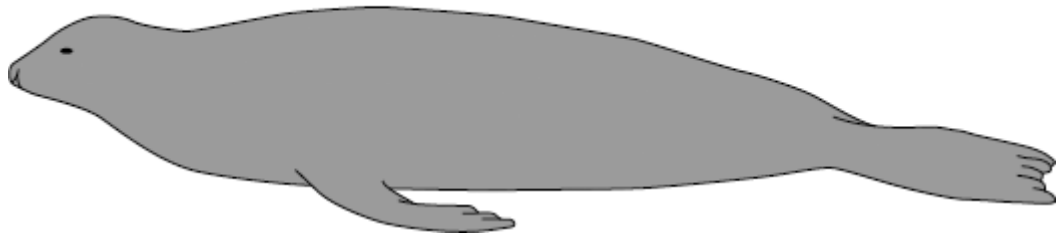

(a) Give **two** ways in which seal **X** is adapted for swimming.

1. _____

2. _____

(2)

(b) This drawing shows seal **Y**, drawn to the same scale as seal **X**.

Seal Y

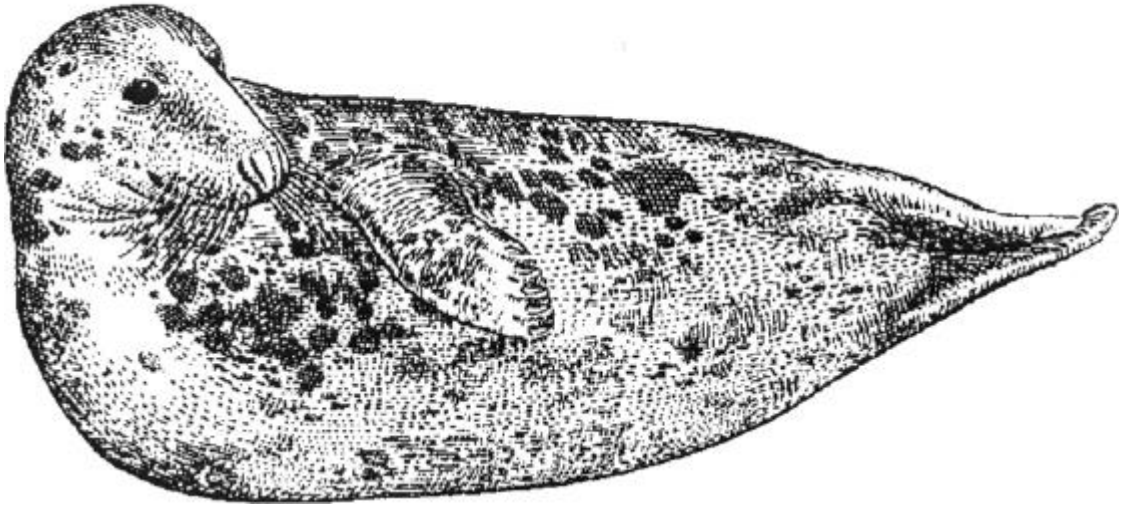

Seal Y lives in much colder seas than seal X.

Explain **one** way in which seal Y is adapted for surviving in cold seas.

(2)
(Total 4 marks)

Q34.

Desert plants are adapted for survival in a dry climate.

- (a) Joshua trees live in deserts.



By nyenyec [CC BY-SA 3.0], via Wikimedia Commons

Joshua trees have two different types of root:

- a system of shallow roots spread out over a large area
- roots about 1 m in diameter, shaped like bulbs, deep in the soil.

Explain the advantage to the Joshua tree of having:

- (i) shallow roots spread out over a large area

(2)

- (ii) large, bulb-like roots deep in the soil.

(1)

- (b) Creosote bushes also live in deserts.



By Sue in az (Own work) [Public domain], via Wikimedia Commons

The leaves of creosote bushes:

- are covered with a layer of wax
- fold together during the day.

Explain how the leaves of the Creosote bush help it to survive in deserts.

(3)

(Total 6 marks)

Q35.

Students investigated the distribution of two plant species near a busy road. The bar chart shows their results.

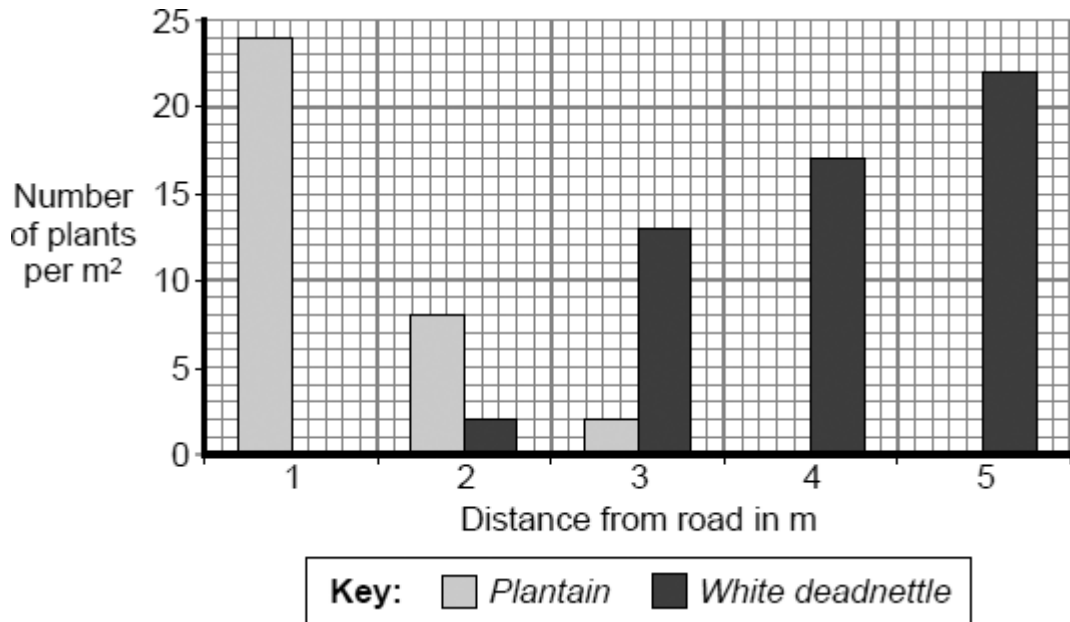

(a) (i) Name the piece of apparatus used in sampling a 1m² piece of land.

(1)

(ii) Describe how this piece of apparatus could be used to obtain the data shown in the bar chart.

(2)

(iii) Describe the pattern shown in the data for the *Plantain* plants.

(1)

(b) Suggest explanations for:

(i) the distribution of the *White deadnettle* plants

(2)

(ii) the distribution of the *Plantain* plants.

(2)

(Total 8 marks)

Q36.

Lichens are sensitive to the amount of sulfur dioxide in the atmosphere. They are used as indicator species for the amount of air pollution. Air pollution is generally higher in town centres than in the countryside.

Students investigated the relationship between lichen species and distance from a town centre.

- On a map, they drew a transect (line) from the centre of the town to the countryside.
- They examined sites every 200 metres along the transect (line).
- At each site, they recorded the lichen species growing on trees and walls up to a height of 2 metres.

The graph shows their results.

The lines on the graph indicate the range of each lichen species.

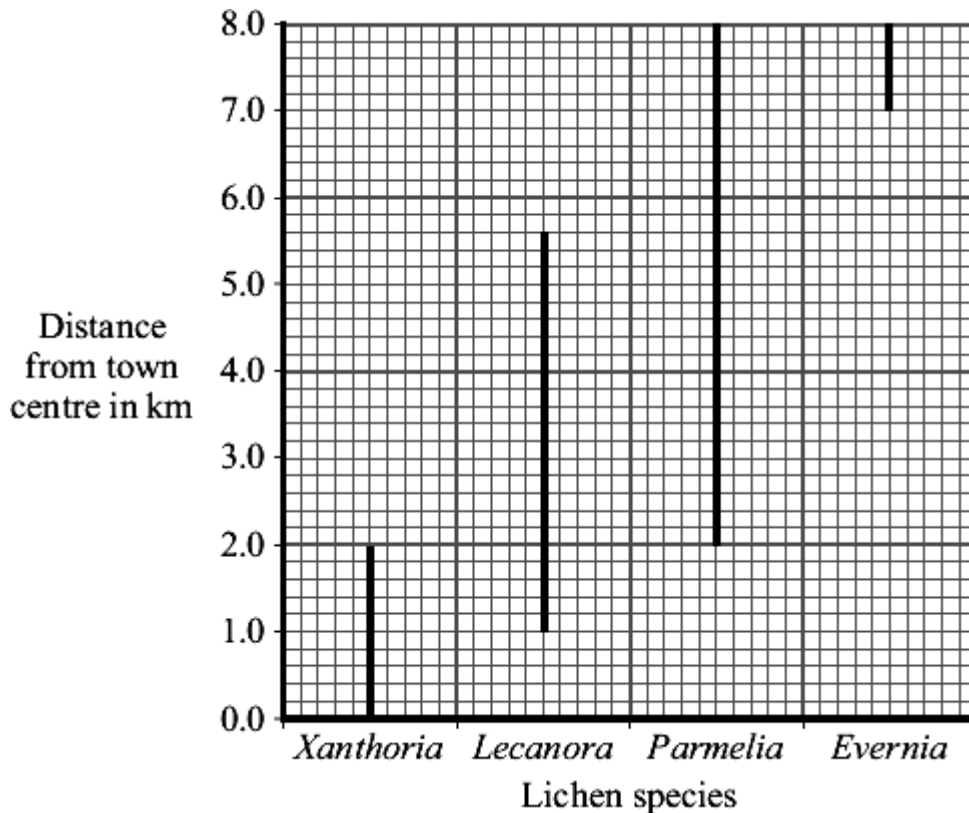

- (a) Give **one** way in which the students could have obtained more accurate results.

(1)

- (b) (i) Which lichen species was found over the greatest range?

(1)

- (ii) Which lichen species grows only in the least polluted air?

(1)

- (c) One student concluded 'You can tell how much sulfur dioxide there is in the air by the amount of *Lecanora* growing'.

Give **two** reasons why this is **not** a valid conclusion.

1. _____

2. _____

(2)

(Total 5 marks)

The photograph shows a musk ox.



Photograph supplied by iStockphoto/Thinkstock

The musk ox lives in the Arctic. An adult musk ox is 2.5 m long and 1.4 m high at the shoulder. Adults usually have a mass of about 400 kg.

Use this information and information from the photograph to explain **two** ways in which a musk ox is adapted for survival in the Arctic.

(a) (i) Adaptation 1 _____ (1)

(ii) How this adaptation helps the musk ox to survive in the Arctic.

(1)

(b) (i) Adaptation 2 _____ (1)

(ii) How this adaptation helps the musk ox to survive in the Arctic.

(1)

(Total 4 marks)

Q38.

Animals in a habitat compete with each other.

(a) Give **two** factors for which animals may compete.

1. _____
2. _____

(2)

(b) The photographs show a mule deer and a white-tailed deer.



Mule deer



White-tailed deer

Mule deer by Dcrjsr (Own work) [CC-BY-3.0], via Wikimedia Commons. White-tailed deer by Clay Heaton (Own work) [CC-BY-SA-3.0], via Wikimedia Commons

Mule deer and white-tailed deer live together in the same national park in the USA.

The graph shows changes in the populations of the two deer species between 1983 and 1999.

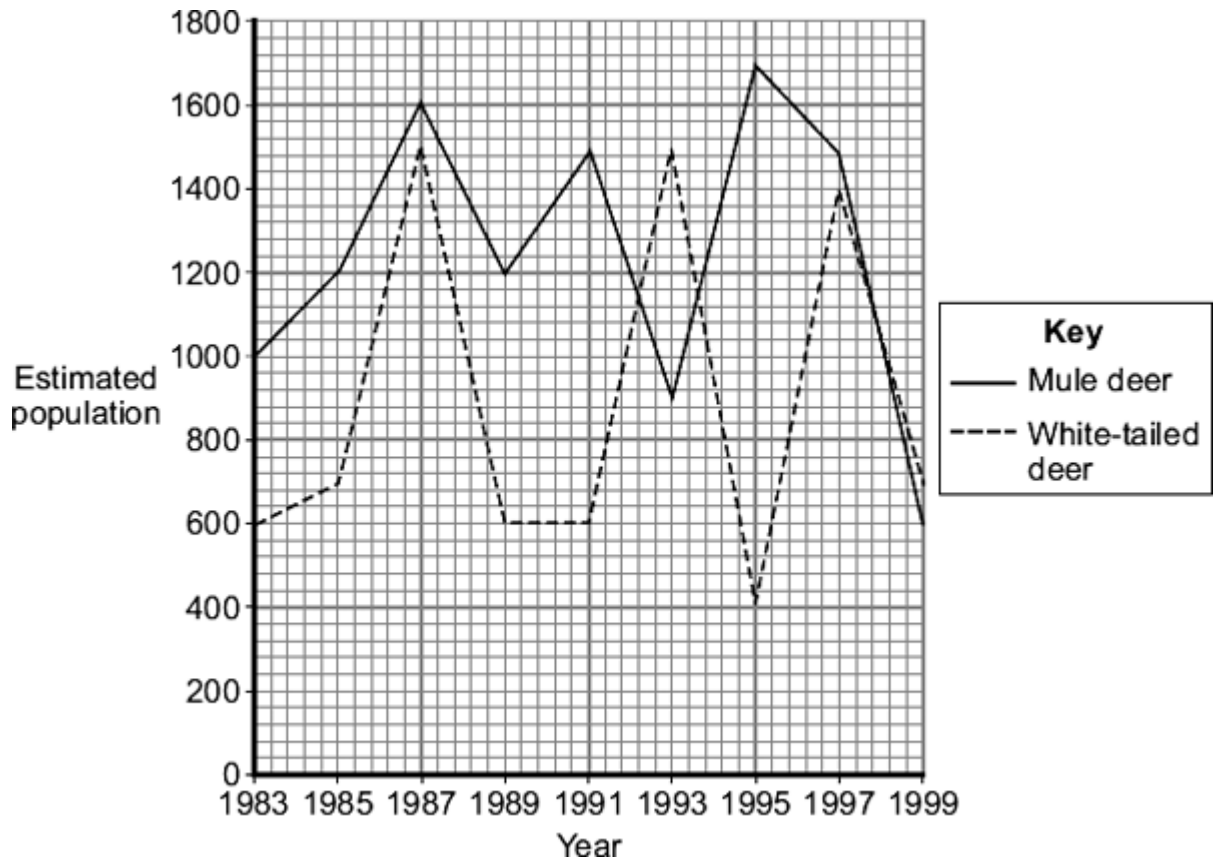

(i) Describe the changes in the population of white-tailed deer between 1991 and 1995.

- (ii) Use information from the graph to suggest an explanation for changes in the population of white-tailed deer between 1991 and 1995.

(2)
(Total 6 marks)

Q39.

In the winter wild birds cannot find food easily.

A student carried out an investigation to find the best kind of food to put out for wild birds in winter.

- She nailed six black dishes to a piece of wood.
- She put 100 g of a different type of seed into each dish.
- She placed the piece of wood in her garden.
- She observed the birds that visited each of the dishes before school, after school and at weekends.
- At the end of the investigation, she weighed the amount of each type of seed remaining.
- She also calculated the percentage of each type of seed that was eaten by the birds.

- (a) Name **two** control variables in this investigation.

1. _____

2. _____

(2)

- (b) **Table 1** shows the number of bird visits to each dish of seeds that she recorded.

Table 1

Bird species	Number of visits to each dish of seeds					
	Corn	Niger	Safflower	Sunflower	Peanut	Millet
Morning Dove	12	10	6	13	2	10
Red-bellied Woodpecker	1	0	0	1	4	0
Dark-eyed Junco	3	6	1	4	0	3

Northern Cardinal	0	0	1	1	2	0
American Goldfinch	0	31	5	18	0	0
House Finch	1	5	23	19	1	3
House Sparrow	16	1	0	4	0	11
Total visits	33	53	36	60	9	27

Which type of seed had visits from the greatest number of **different** bird species?

(1)

- (c) **Table 2** shows:
- the percentage of each type of seed eaten
 - the percentage of fat in each type of seed.

Table 2

Type of seed	Percentage eaten	Percentage of fat
Corn	68	2
Niger	77	40
Safflower	86	3
Sunflower	91	35
Peanut	4	48
Millet	99	2

- (i) The girl concluded that the most popular seeds for the birds were the seeds with the highest percentage of fat.

Was her conclusion justified by the data in **Table 2**?

Draw a ring round your answer. **Yes / No**
Give a reason for your answer.

(1)

- (ii) Most winter bird food for sale in shops contains niger and sunflower seeds. Use the information in **Table 1** and **Table 2** to suggest **two** reasons why.

1. _____

2. _____

(2)

(Total 6 marks)

Q40.

Some students investigated the distribution of some of the plants growing in and around a shallow stream. They sampled along a transect line.

The diagram shows their results.

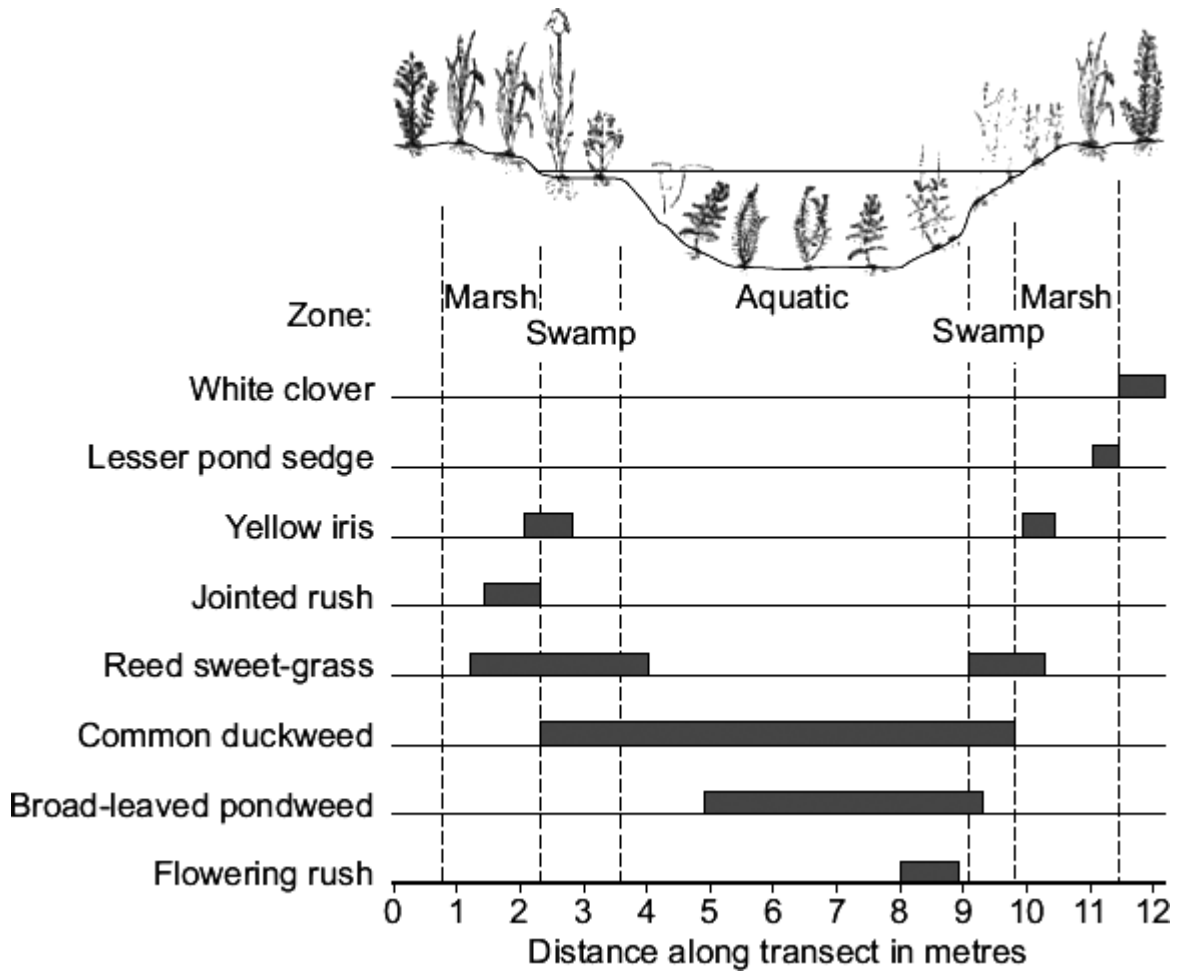

(a) (i) Name the **one** species that grew only in the driest conditions.

(1)

(ii) Only **one** species grew in the marsh, the swamp and in the aquatic zones.

Which species?

(1)

(iii) Duckweed grows floating in water. What evidence is there for this in the students' results?



By Albert Kok at nl.wikipedia [Public domain], from Wikimedia Commons

In 1992 six lionfish escaped from an aquarium into the Atlantic Ocean.

Now there are thousands of lionfish in the Atlantic Ocean. Numbers of the native Atlantic fish have gone down because the lionfish have eaten many native Atlantic fish.

Suggest explanations for the large increase in the number of lionfish in the Atlantic Ocean.

(3)

(Total 3 marks)

Q42.

In this question you will be assessed on using good English, organising information clearly and using specialist terms where appropriate.

Plants and animals have become adapted in many different ways to reduce the risk of being eaten by predators.

Describe these adaptations.

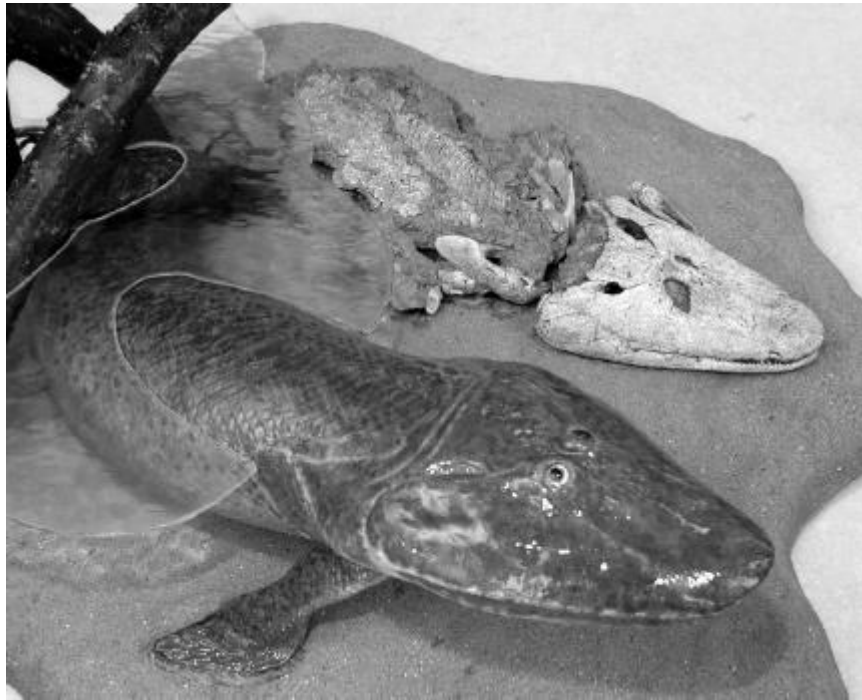

Image © University of Chicago, Shubin Lab. Model by Tyler Keillor

- (a) Scientists found only the fossilised skeleton of *Tiktaalik*.

Explain why.

(2)

- (b) Scientists think that *Tiktaalik* lived mostly in water, but that it was one of the first animals to be able to move onto land.

Use evidence from the photograph to suggest why.

(2)

(Total 4 marks)

Q44.

Fruits contain seeds. Most plants produce fruits that are adapted for dispersing seeds. Seeds are dispersed so that young plants do not grow near their parents.

- (a) Explain the advantage to plants of dispersing their seeds.

(2)

(b) The photograph shows cocklebur fruits.



Photograph by Robert H. Mohlenbrock. Image in the public domain as a work of the U.S. federal government. Courtesy of USDA NRCS Wetland Science Institute.

The photograph is magnified.

Suggest how cocklebur fruits are adapted for dispersing their seeds.

(2)

(Total 4 marks)

Q45.

Penguins live mainly in the Antarctic. Penguins eat mainly fish.
Photograph 1 shows a penguin swimming underwater.

Photograph 1



© raywooi/Stock

(a) Use information from **Photograph 1** to suggest **three** ways the penguin is adapted for catching fish.

1. _____

2. _____

3. _____

(3)

(b) The Antarctic winter is very cold. In the winter some species of penguin huddle together as shown in **Photograph 2**.

Photograph 2



© Fuse

Suggest how the behaviour shown in **Photograph 2** helps the penguins to survive the Antarctic winter.

(3)

- (c) A student did an investigation to model the behaviour of the penguins shown in **Photograph 2**.

The diagram shows the apparatus the student used.

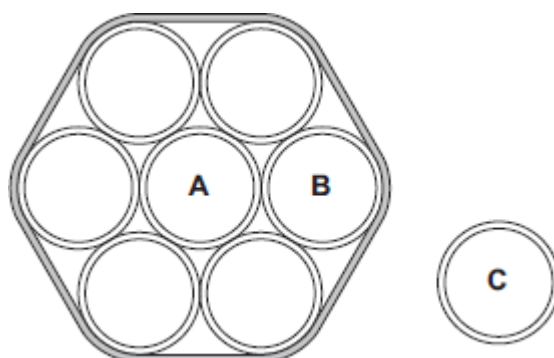

The student:

- held seven similar test tubes together with elastic bands as shown in the diagram
- stood a similar eighth tube in a test tube rack
- filled each of the eight tubes with hot water to the same level
- measured the temperature of the water in tubes **A**, **B** and **C** every 2 minutes for 20 minutes.

The table shows the student's results.

Time in Minutes	Temperature in °C		
	Tube A	Tube B	Tube C
0	65	65	65
2	65	65	64
4	65	64	63
6	64	64	62
8	64	63	61
10	64	63	60
12	63	62	59

14	63	62	58
16	63	61	57
18	62	61	56
20	62	60	55

(i) Give **two** variables that were controlled in the investigation.

1. _____

2. _____

(2)

(ii) Describe the patterns the data shows.

(2)

(iii) How far does the data from the model support the suggestion you made in part **(b)**?

(2)

(d) Describe how blood vessels help control human body temperature.

(4)

(e) Penguins control their body temperature in similar ways to humans. Scientists investigated changes in body temperature of penguins when the penguins

were diving to catch fish.

- (i) **Graph 1** shows the relationship between the temperature of the muscles moving a penguin's wings and diving.

The shaded areas show when the penguin was diving.

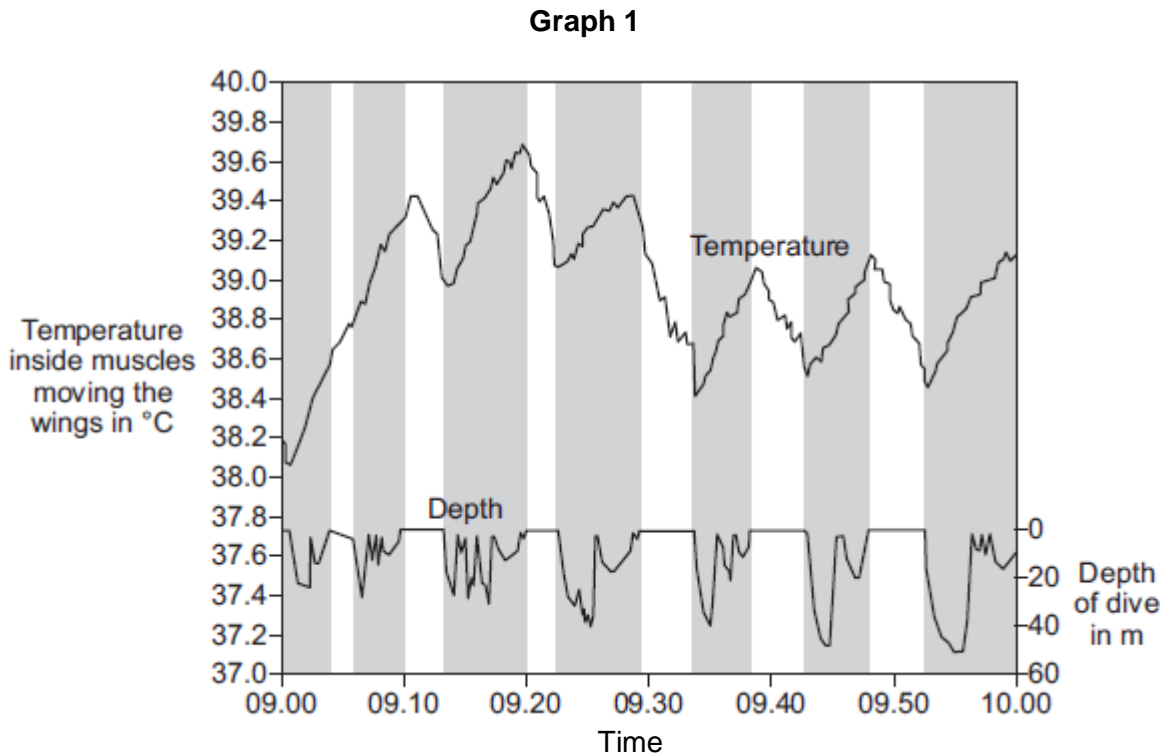

© Reprinted from Comparative Biochemistry and Physiology Part A: Molecular & Integrative Physiology, Volume 135, P.J. Ponganis, R.P. Van Dam, D.H. Levenson, T. Knowler, K.V. Ponganis, G. Marshall, Regional heterothermy and conservation of core temperature in emperor penguins diving under sea ice, pp 477-487, copyright 2003, with permission from Elsevier

Suggest an explanation for the changes in temperature inside the muscles moving the penguin's wings.

(3)

- (ii) **Graph 2** shows the relationship between the temperature inside a penguin's foot and diving.

The shaded areas show when the penguin was diving.

Graph 2

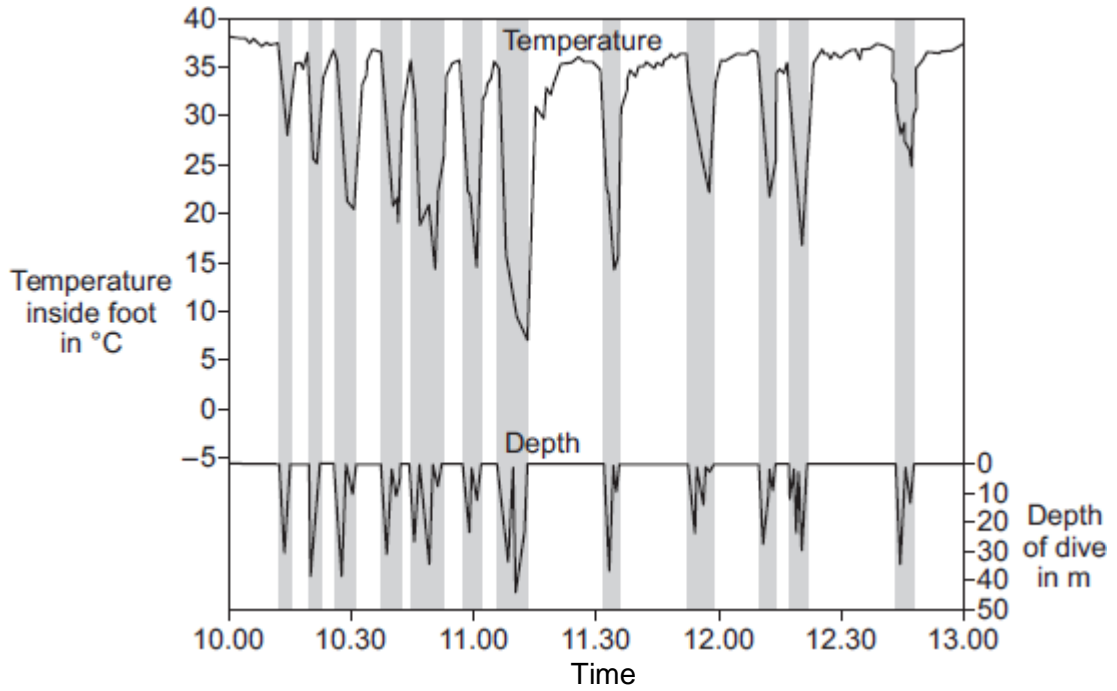

© Reprinted from Comparative Biochemistry and Physiology Part A: Molecular & Integrative Physiology, Volume 135, P.J. Ponganis, R.P. Van Dam, D.H. Levenson, T. Knower, K.V. Ponganis, G. Marshall, Regional heterothermy and conservation of core temperature in emperor penguins diving under sea ice, pp 477-487, copyright 2003, with permission from Elsevier

Suggest an explanation for the changes in temperature inside the penguin's foot as it dives.

(3)
(Total 22 marks)

Q46.

In this question you will be assessed on using good English, organising information clearly and using specialist terms where appropriate.

The diagram shows part of the carbon cycle.

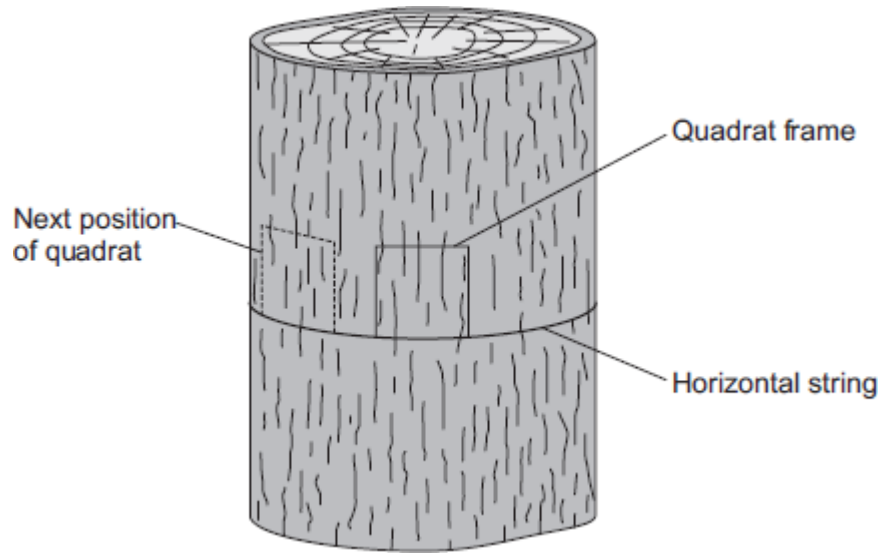

The students:

- tied a piece of string horizontally round a tree
- put a quadrat on the string so that the quadrat faced south
- estimated the percentage of the area in the quadrat covered with the green alga
- repeated the observation with the quadrat facing south west, west, north west, north, north east, east and south east.

(a) The diagram shows the quadrat the students used.

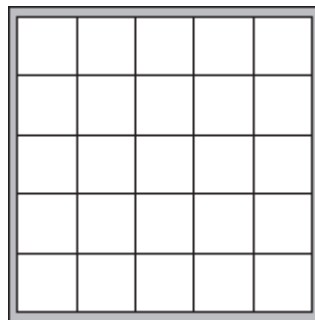

Describe how you would estimate the percentage of the area covered with the green alga in one quadrat.

(2)

(b) The bar chart shows the students' results.

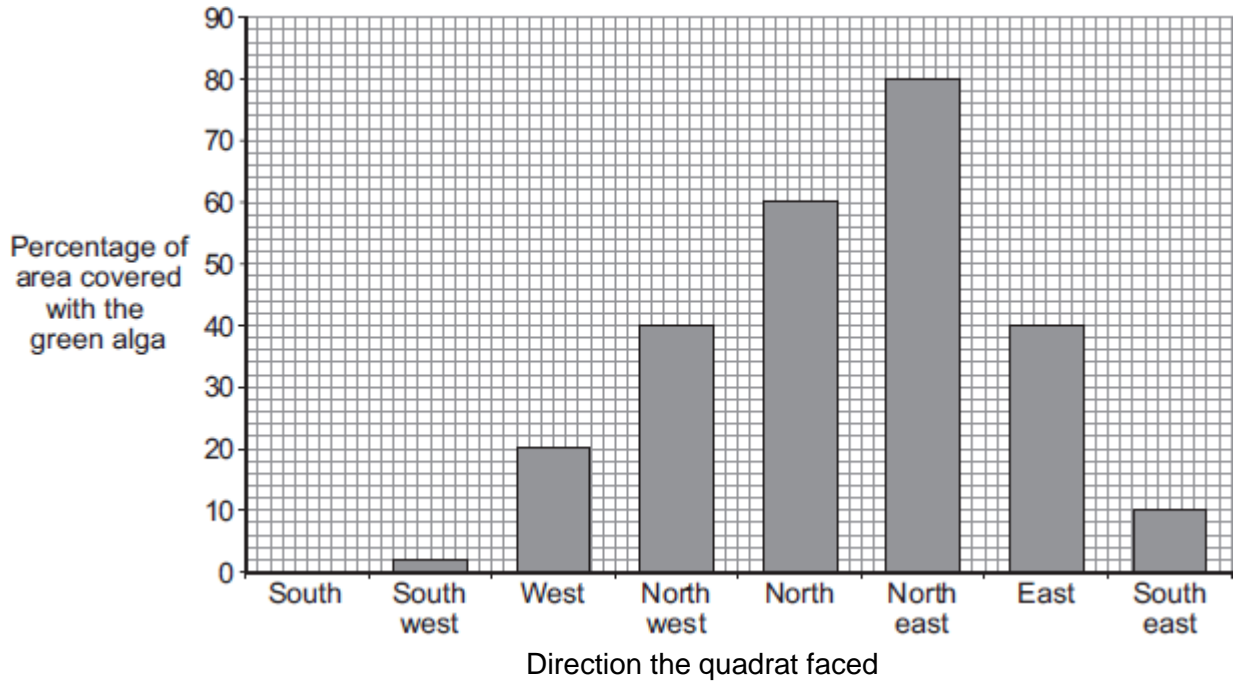

(i) How does the direction that the quadrat faced affect the percentage area covered with the green alga?

(2)

(ii) What was the mode of the percentage area covered with the green alga?

Mode = _____ %

Give the reason for your answer.

(2)

(iii) Give **three** environmental factors that might affect the distribution of the green alga on the tree.

1. _____
2. _____
3. _____

(3)

(iv) Suggest how **one** of the factors you gave in part (b) (iii) might have caused the distribution of the green alga shown on the bar chart.

Factor _____

(3)

- (c) Nitrophyte lichens grow on the bark of trees. These lichens are indicators of air pollution by ammonia. Ammonia concentrations in the atmosphere are often high in agricultural areas. The graph shows the relationship between air quality and the distribution of nitrophyte lichens.

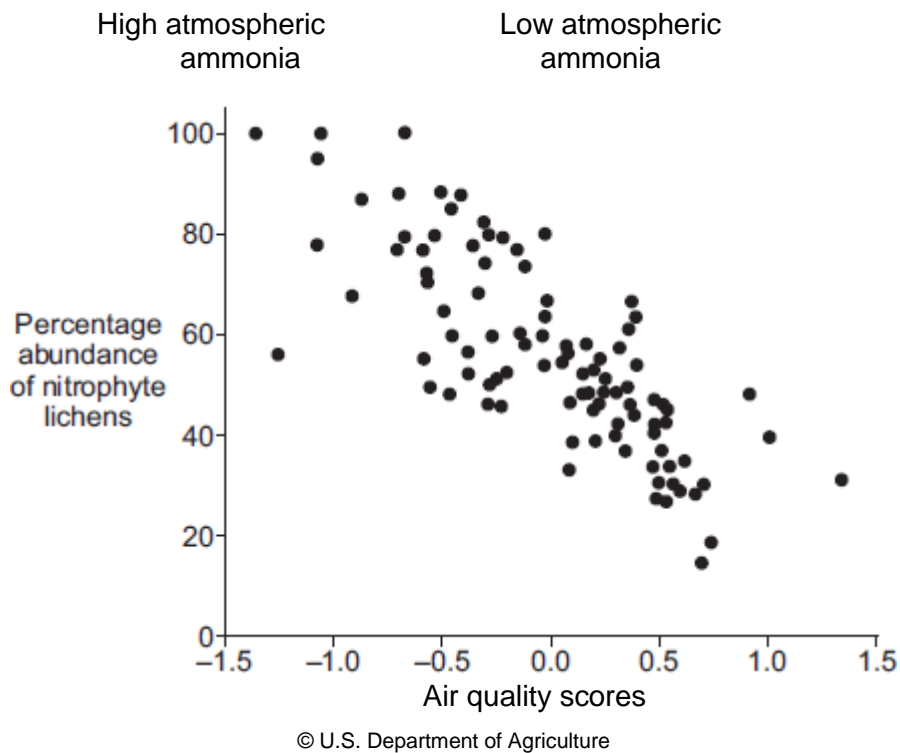

- (i) Describe the relationship between atmospheric ammonia and the abundance of nitrophyte lichens.

(2)

- (ii) How useful would a particular value for the abundance of nitrophyte lichens be as an indicator of ammonia pollution of the atmosphere? Explain your answer.

Q48.

Peas grow in pods on pea plants.

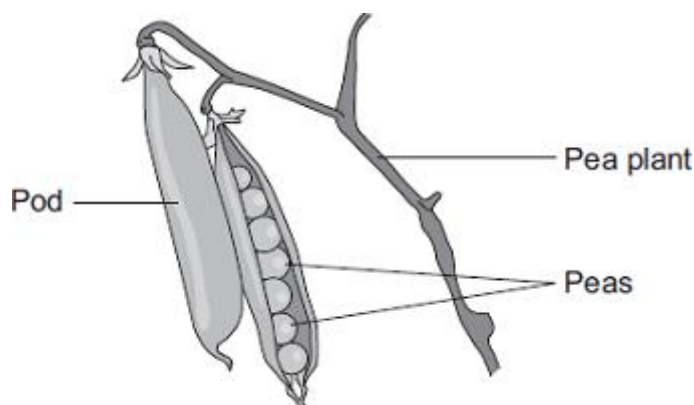

A gardener grew four varieties of pea plants, **A**, **B**, **C** and **D**, in his garden. The gardener counted the number of peas in each pod growing on each plant.

The table shows his results.

Variety	Range of number of peas in each pod	Mean number of peas in each pod
A	2–6	4
B	3–7	5
C	3–8	6
D	6–8	7

- (a) Give **one** environmental factor and **one other** factor that might affect the number of peas in a pod.

Environmental factor _____

Other factor _____

(2)

- (b) The gardener thinks that he will get the largest mass of peas from his garden if he grows variety **D**.

Why is the gardener **not** correct?

Suggest **one** reason.

Explain how each adaptation helps the arctic fox to survive in very cold conditions.

Adaptation 1 _____

How this adaptation helps the arctic fox to survive in very cold conditions.

Adaptation 2 _____

How this adaptation helps the arctic fox to survive in very cold conditions.

(4)

(b) The photograph shows an antelope that lives in a sandy desert.



By Sun417 at zh.wikipedia [Public domain],
from Wikimedia Commons

The antelope is prey to large cats such as cheetahs.

Suggest **one** adaptation that helps this antelope avoid being killed by predators.

Explain how this adaptation helps the antelope avoid being killed by predators.

Adaptation _____

How this adaptation helps the antelope avoid being killed by predators.

(2)

(Total 6 marks)

Q50.

Deforestation affects the environment in many ways.

- (a) Deforestation increases the amount of carbon dioxide in the atmosphere.

Give **two** reasons why.

1. _____

2. _____

(2)

- (b) Deforestation also results in a loss of *biodiversity*.

- (i) What is meant by *biodiversity*?

(1)

- (ii) Give **two** reasons why it is important to prevent organisms becoming extinct.

1. _____

2. _____

(2)

(Total 5 marks)

Q51.

In this question you will be assessed on using good English, organising information clearly and using specialist terms where appropriate.

Deforestation affects the environment.

Deforestation is causing a change in the amounts of different gases in the atmosphere. This change causes global warming and climate change.

The image below shows an area of deforestation.

Q52.

The lugworm lives in a U-shaped burrow in the sand on the seashore.

The diagram below shows a lugworm in its burrow.

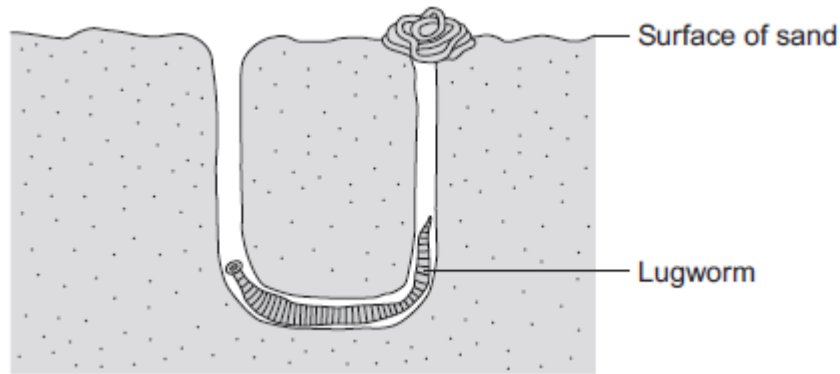

(a) Some scientists investigated the effect of different salt concentrations on lugworms.

The scientists:

- collected 50 lugworms from the seashore
- separated them into five groups of 10 lugworms
- weighed each group of 10 lugworms
- placed each group into a different concentration of salt solution and left them for 8 hours
- took each lugworm out of the solution and placed it on blotting paper for 30 seconds
- re-weighed each group of 10 lugworms.

(i) Why did the scientists use groups of 10 lugworms and not just 1 lugworm at each concentration?

(1)

(ii) Suggest why the scientists placed each lugworm on blotting paper for 30 seconds before they reweighed the groups of lugworms.

(1)

(iii) How might the method of blotting have caused errors in the results?

(1)

(iv) Suggest **one** improvement the scientists could make to their investigation.

(1)

(b) The table below shows the scientists' results.

Concentration of salt in arbitrary units	Mass of 10 lugworms at start in grams	Mass of 10 lugworms after 8 hours in grams	Change in mass in grams	Percentage (%) change in mass
1.0	41.2	61.8	+20.6	+50
2.0	37.5	45.0	+7.5	
3.0	55.0	56.1	+1.1	+2
4.0	46.2	22.2	-24.0	-52
5.0	45.3	22.6	-22.7	-50

(i) The scientists calculated the **percentage** change in mass at each salt concentration.

Why is the **percentage** change in mass more useful than just the change in mass in grams?

Use information from the table in your answer.

(2)

(ii) Calculate the percentage change in mass for the 10 lugworms in the salt solution with a concentration of 2.0 arbitrary units.

Percentage change in mass = _____ %

(2)

(c) (i) On the graph paper below, draw a graph to show the scientists' results:

- plot the **percentage** change in mass
- label the horizontal axis
- draw a line of best fit.

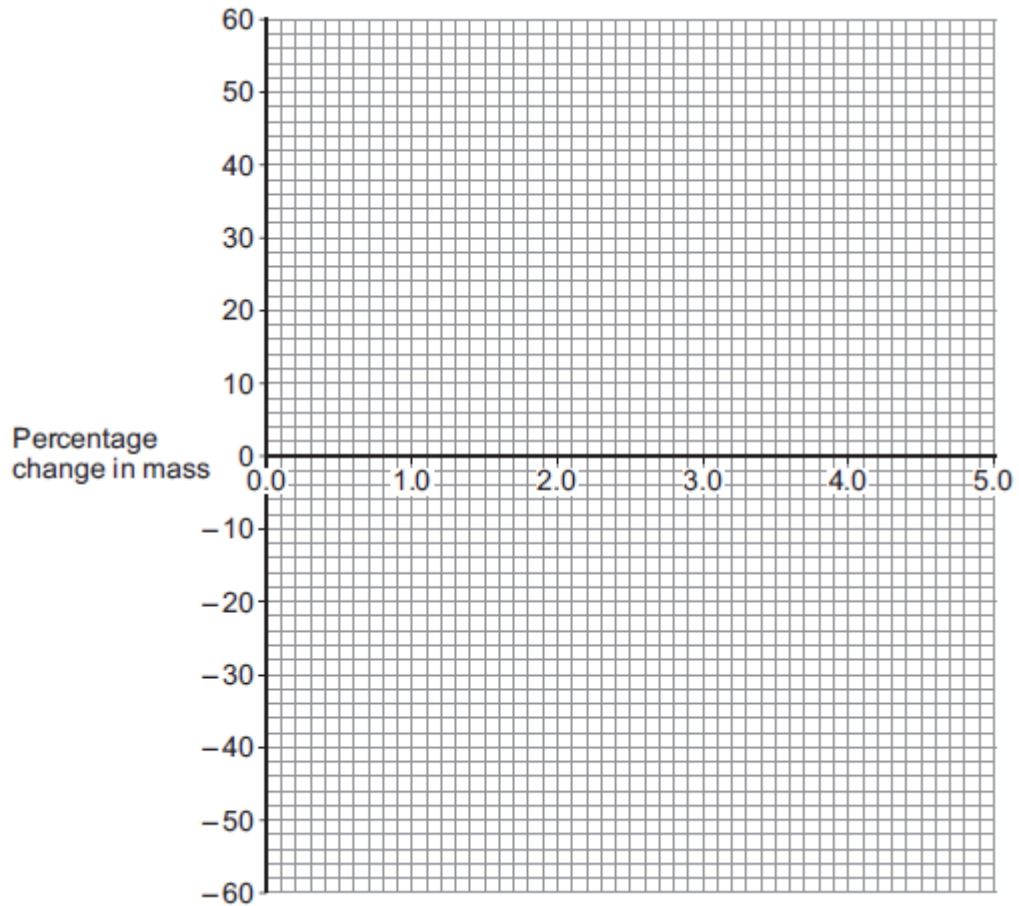

(4)

(ii) The scientists thought one of their results was anomalous.

Draw a ring around the anomalous result on your graph.

(1)

(iii) Suggest what might have happened to cause this anomalous result.

(1)

(d) (i) What do you think is the concentration of salts in the lugworm's natural environment?

Use information from your graph to give the reason for your answer.

Concentration = _____ %

Reason _____

(2)

(ii) The mass of the lugworms decreased in the salt solution with a concentration of 5.0 arbitrary units.

Explain what caused this.

(3)
(Total 19 marks)

Q53.

Freshwater streams may have different levels of pollution. The level of pollution affects which species of invertebrate will live in the water.

Table 1 shows the biomass of different invertebrate species found in two different streams, **X** and **Y**.

Table 1

Invertebrate species	Biomass in g	
	Stream X	Stream Y
Mayfly nymph	4	0
Caddis fly larva	30	0
Freshwater shrimp	70	5
Water louse	34	10
Bloodworm	10	45
Sludge worm	2	90
Total	150	150

(a) The bar chart below shows the biomass of invertebrate species found in **Stream X**.

(i) Complete the bar chart by drawing the bars for water louse, bloodworm and sludge worm in **Stream Y**.

Use the data in **Table 1**.

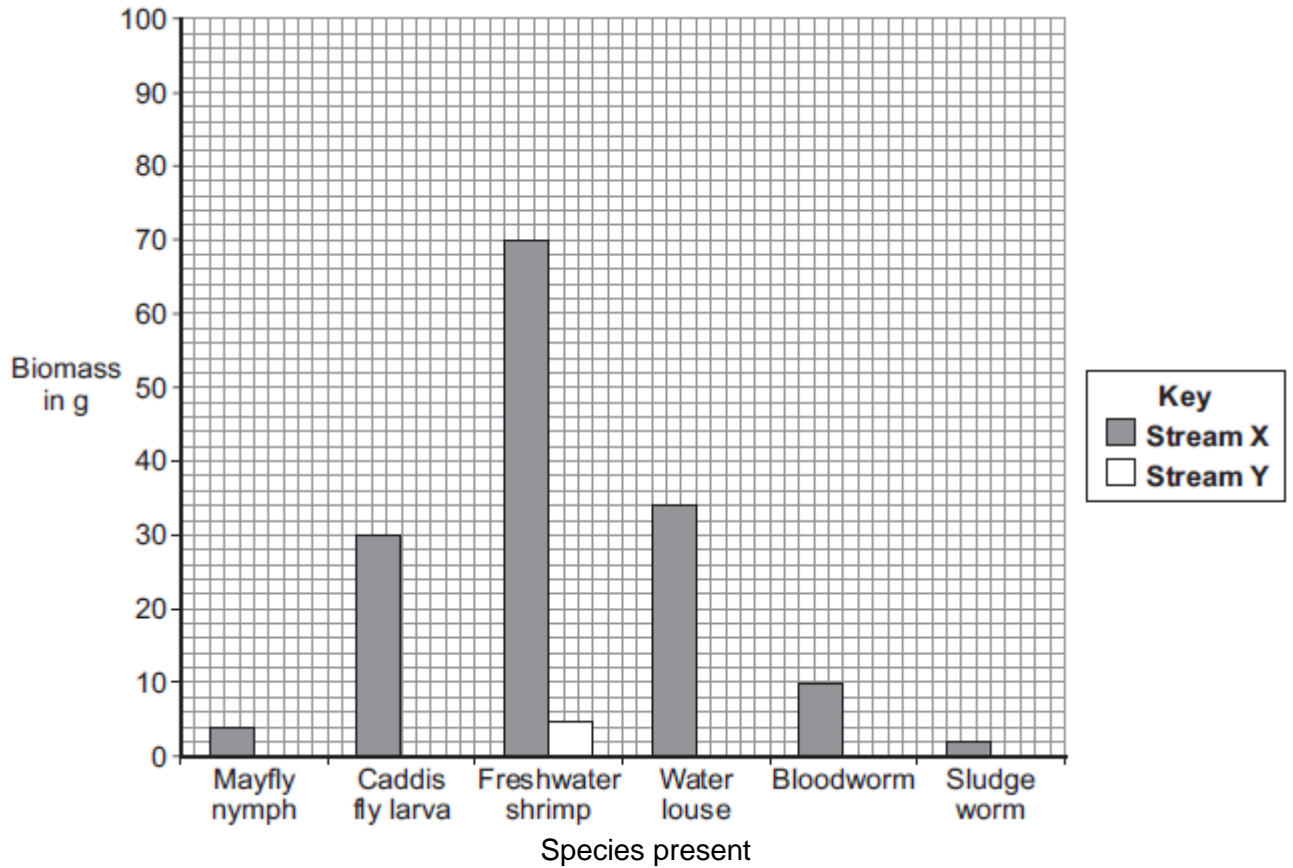

(2)

(ii) **Table 2** shows which invertebrates can live in different levels of water pollution.

Table 2

Pollution level	Invertebrate species likely to be present
Clean water	Mayfly nymph
Low pollution	Caddis fly larva, Freshwater shrimp
Medium pollution	Water louse, Bloodworm
High pollution	Sludge worm

Which stream, **X** or **Y**, is more polluted?

Use the information from **Table 1** and **Table 2** to justify your answer.

(2)

(b) There is a sewage works near another stream, **Z**.

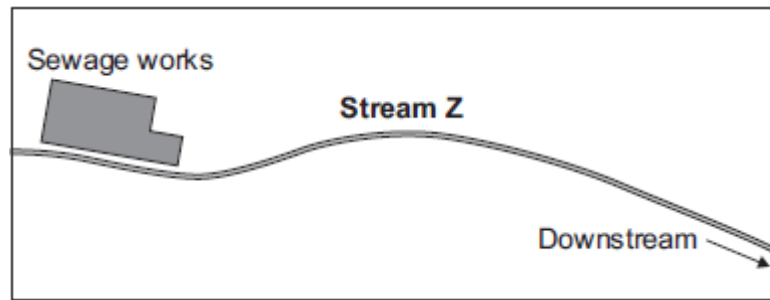

An accident caused sewage to overflow into **Stream Z**.
 Two weeks later scientists took samples of water and invertebrates from the stream.
 They took samples at different distances downstream from where the sewage overflowed.
 The scientists plotted the results shown in **Graphs P** and **Q**.

Graph P: change in water quality downstream of sewage overflow

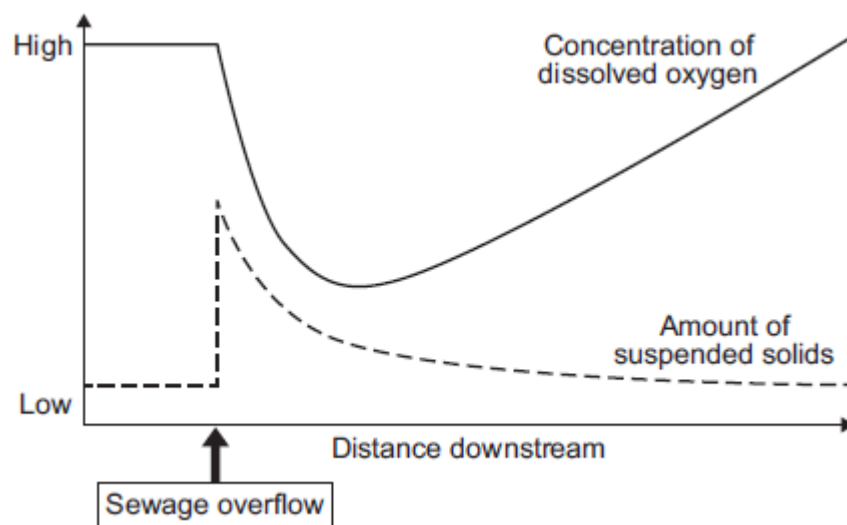

Graph Q: change in invertebrates found downstream of sewage overflow

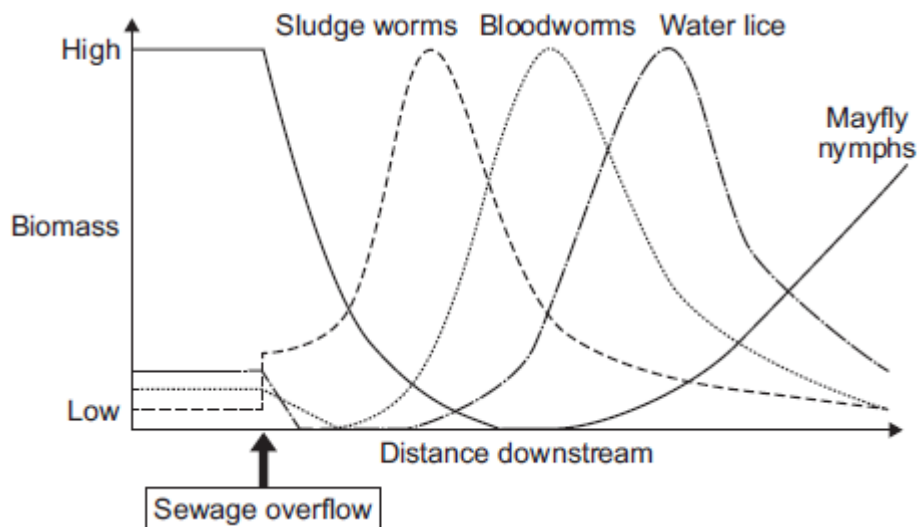

(i) Describe the patterns shown in **Graph P**.

(4)

- (ii) Describe the relationship between dissolved oxygen and the survival of mayfly nymphs in **Stream Z**. Suggest a reason for the pattern you have described.

(3)

- (c) Many microorganisms are present in the sewage overflow.

Explain why microorganisms cause the level of oxygen in the water to decrease.

(2)

(Total 13 marks)

Q54.

A project called Garden Bird Watch counts the UK populations of common birds. 16 000 people count the number of birds in their gardens every week of the year.

The results are analysed by researchers and written up in important scientific magazines.

- (a) Suggest **one** advantage of this method of collecting data.

The table below shows the percentage (%) of gardens visited by different bird species in 1995 and in 2011.

Bird species	% of gardens visited in 1995	% of gardens visited in 2011
Goldfinch	12	58
Greenfinch	71	54
House sparrow	84	64
Starling	71	42
Woodpigeon	48	80

(1)

- (b) (i) Complete the bar chart below, by plotting the data from the table above for 2011.

Some have been done for you.

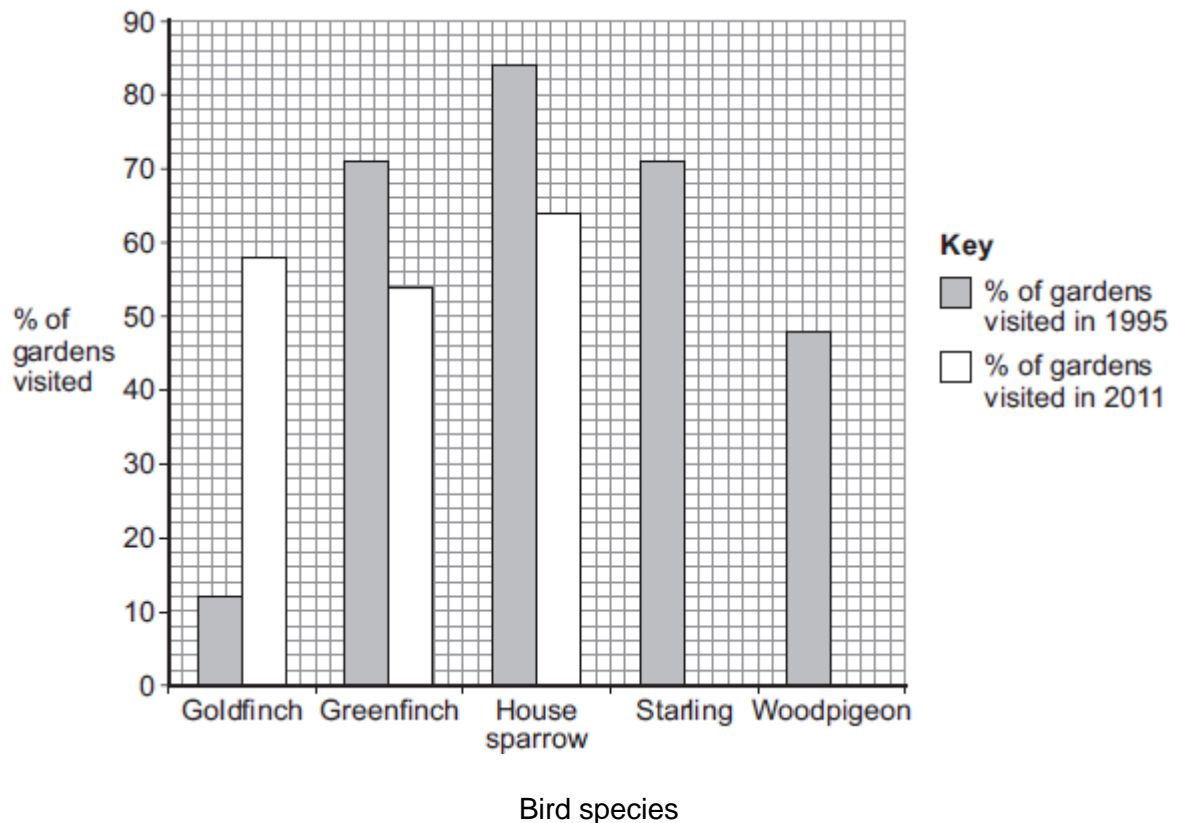

(2)

- (ii) In this survey, the results from 16 000 gardens were sent in.

How many gardens were visited by woodpigeons in 2011?

(2)

- (iii) Which bird species has increased the most from 1995 to 2011?

(1)

- (c) The change in the number of wood pigeons may be partly because they have spread to towns and cities.
Suggest why this increase in wood pigeons in towns and cities might have occurred.

(1)

(Total 7 marks)

Q55.

The diagram below shows a single-celled alga which lives in fresh water.

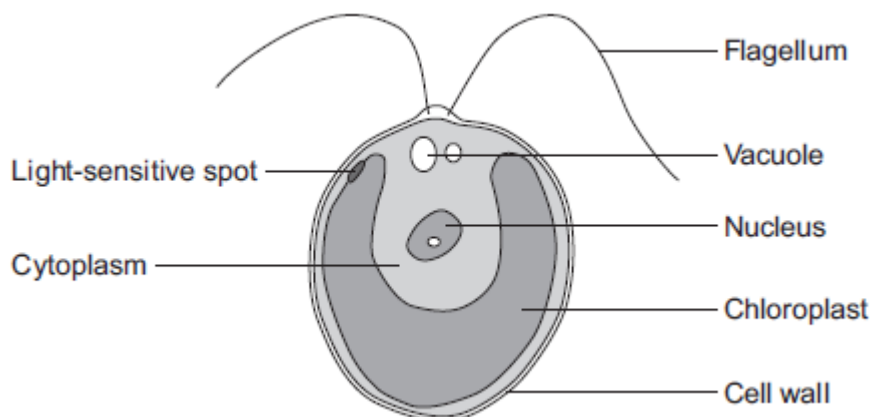

- (a) Which part of the cell labelled above:

- (i) traps light for photosynthesis

(1)

- (ii) is made of cellulose?

(1)

- (b) In the freshwater environment water enters the algal cell.

- (i) What is the name of the process by which water moves into cells?

(1)

- (ii) Give the reason why the algal cell does not burst.

(1)

- (c) (i) The alga can photosynthesise.

Complete the **word** equation for photosynthesis.

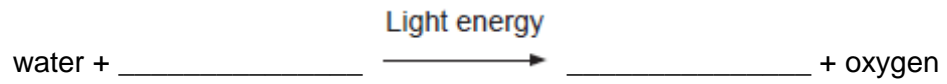

(2)

- (ii) The flagellum helps the cell to move through water. Scientists think that the flagellum and the light-sensitive spot work together to increase photosynthesis.

Suggest how this might happen.

(2)

- (d) Multicellular organisms often have complex structures, such as lungs, for gas exchange.

Explain why single-celled organisms, like algae, do **not** need complex structures for gas exchange.

(3)

(Total 11 marks)

Q56.

A grassy field on a farm measured 120 metres by 80 metres.

A student wanted to estimate the number of buttercup plants growing in the field.

The student found an area where buttercup plants were growing and placed a 1 m × 1 m quadrat in one position in that area.

Figure 1 shows the buttercup plants in the quadrat.

Figure 1

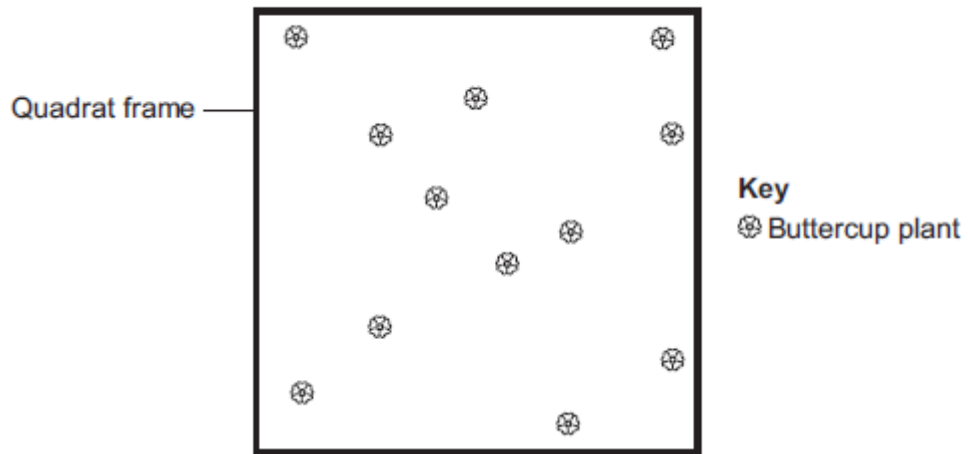

The student said, 'This result shows that there are 115 200 buttercup plants in the field.'

- (a) (i) How did the student calculate that there were 115 200 buttercup plants in the field?

(2)

- (ii) The student's estimate of the number of buttercup plants in the field is probably not accurate. This is because the buttercup plants are not distributed evenly.

How would you improve the student's method to give a more accurate estimate?

(2)

- (b) Sunlight is one environmental factor that might affect the distribution of the buttercup plants.

- (i) Give **three other** environmental factors that might affect the distribution of the buttercup plants.

1. _____

2. _____

3. _____

(3)

(ii) Explain how the amount of sunlight could affect the distribution of the buttercup plants.

(3)

(c) **Figure 2** is a map showing the position of the farm and a river which flows through it.

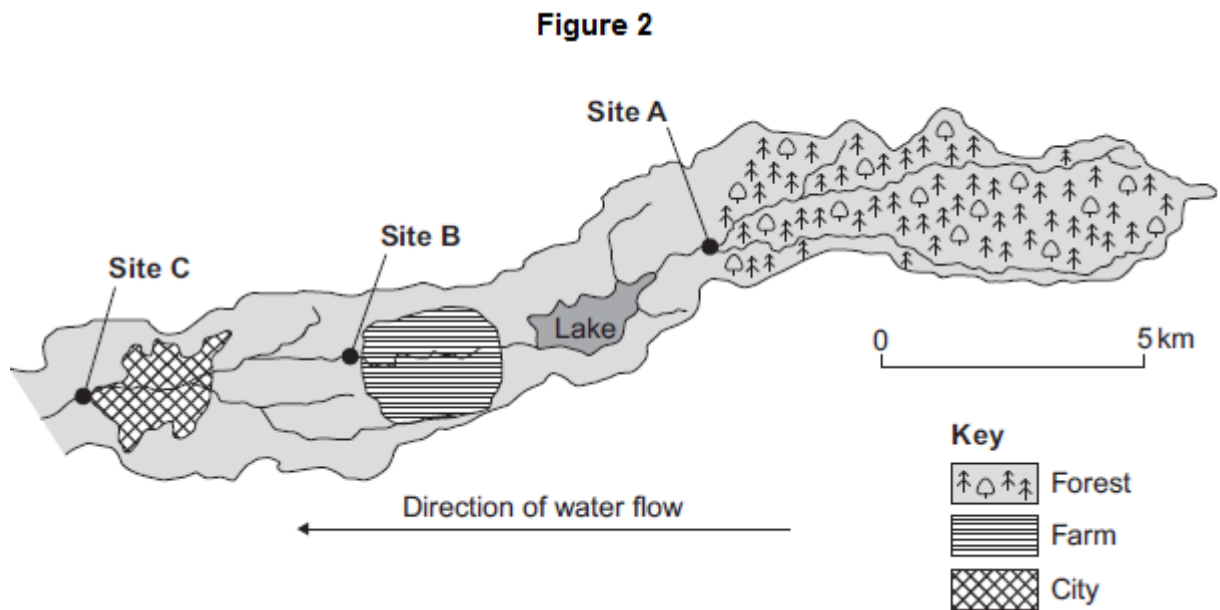

Every year, the farmer puts fertiliser containing mineral ions on some of his fields. When there is a lot of rain, some of the fertiliser is washed into the river.

(i) When fertiliser goes into the river, the concentration of oxygen dissolved in the water decreases.

Explain why the concentration of oxygen decreases.

(5)

(ii) There is a city 4 km downstream from the farm.

Apart from fertiliser, give **one** other form of pollution that might go into the river as it flows through the city.

(d) Three sites, **A**, **B** and **C**, are shown in **Figure 2**.

Scientists took many samples of river water from these sites.

The scientists found larvae of three types of insect in the water: mayfly, stonefly and caddisfly. For each type of insect the scientists found several different species.

The scientists counted the number of different species of the larvae of each of the three types of insect.

Figure 3 shows the scientists' results.

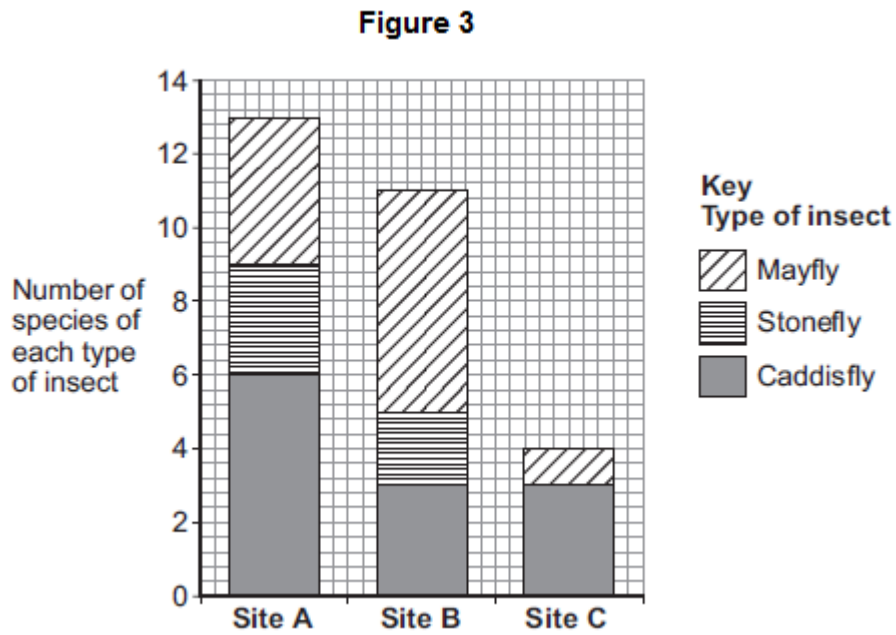

(i) How many more species of mayfly were there at Site **B** than at Site **A**?

_____ (1)

(ii) Suggest what caused this increase in the number of species of mayfly.

_____ (1)

(iii) The scientists stated that the number of species of stonefly was the best indicator of the amount of oxygen dissolved in the water.

Use information from **Figure 3** to suggest why.

(1)
(Total 19 marks)

Q57.

This question is about carbon.

The graph shows the mass of carbon added to and removed from the atmosphere each

year.

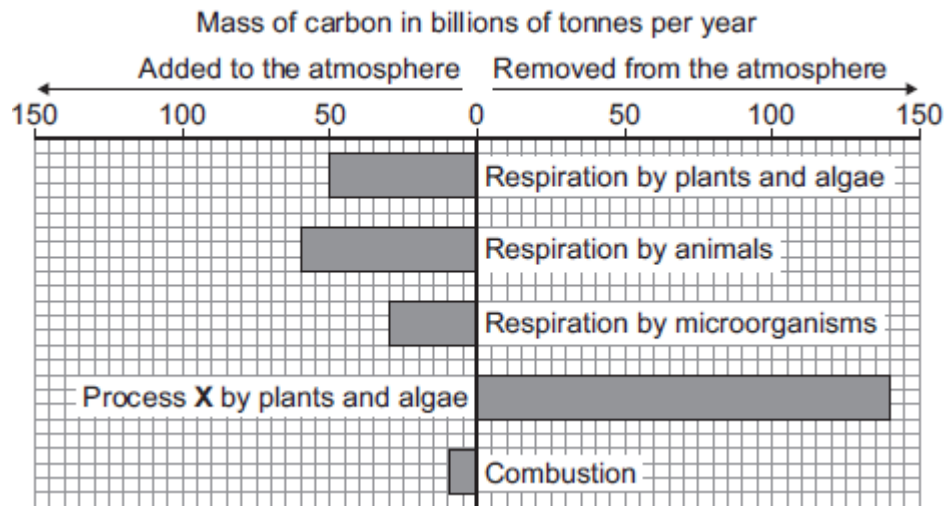

(a) Name process X.

_____ (1)

(b) (i) Calculate the mass of carbon added to the atmosphere by respiration per year.

Answer = _____ billion tonnes (1)

(ii) Some scientists are concerned that the mass of carbon in the atmosphere is changing.

How does the data in the graph support this idea?

(1)

(Total 3 marks)

Q58.

The photograph shows a fossil of a prehistoric bird called *Archaeopteryx*.

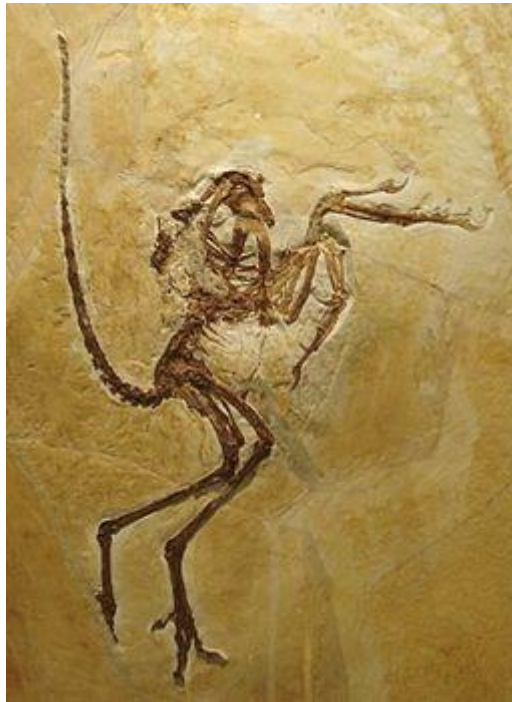

By Ghedoghedo (own work) [CC-BY-SA-3.0 (<http://creativecommons.org/licenses/by-sa/3.0>) or GFDL (<http://www.gnu.org/copyleft/fdl.html>)], via Wikimedia Commons; By Steenbergs from Ripon, United Kingdom (Small Fishing Boat In North Sea) [CC-BY-2.0 (<http://creativecommons.org/licenses/by/2.0>)], via Wikimedia Commons.

(a) Describe **three** ways fossils can be made.

(3)

(b) The drawing shows what an *Archaeopteryx* might have looked like when it was alive.

Scientists think that *Archaeopteryx* was a predator.

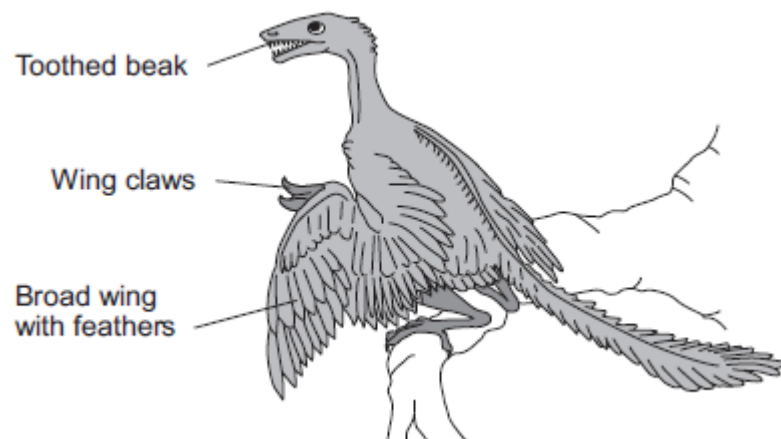

(i) Look at the drawing.

Write down **three** adaptations that might have helped *Archaeopteryx* to catch prey.

How would **each** adaptation have helped *Archaeopteryx* to catch prey?

Adaptation 1 _____

How it helps _____

Adaptation 2 _____

How it helps _____

Adaptation 3 _____

How it helps _____

(3)

(ii) *Archaeopteryx* is now extinct.

Give **two** reasons why animals may become extinct.

1. _____

2. _____

(2)

(Total 8 marks)

Q59.

Organisms compete with each other.

(a) **Figure 1** shows two types of seaweed which live in similar seashore habitats.

Figure 1

Saw wrack



© Nigel Downer/Science Photo Library

Bladder wrack



Bladders filled with air

© Colin13362/iStock/Thinkstock

Most of the time the two seaweeds are covered with water.

Bladder wrack has bladders filled with air.

Bladder wrack grows more quickly than saw wrack.
Suggest an explanation why.

(3)

(b) **Figure 2** shows an angler fish.

Figure 2

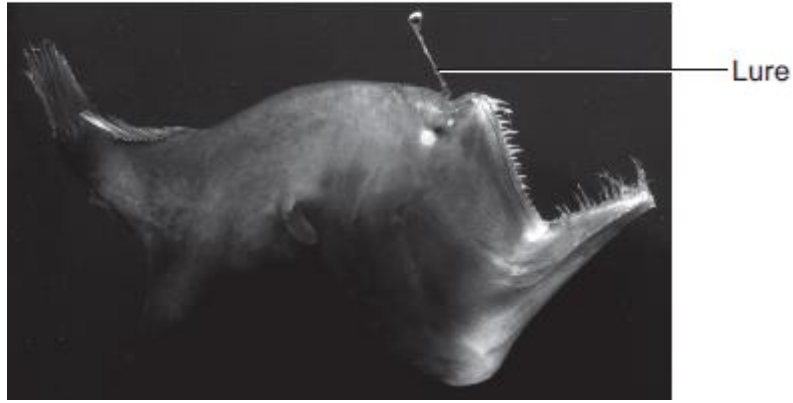

© Dante Fenolio/Science Photo Library

Angler fish live at depths of over 1000 m.

In clear water, sunlight does not usually reach more than 100 m deep.
Many angler fish have a transparent 'lure' containing a high concentration of bioluminescent bacteria.
Bioluminescent bacteria produce light.

Suggest an advantage to the angler fish of having a lure containing bioluminescent bacteria.

(2)

(Total 5 marks)

Q60.

Human activities have many effects on our ecosystem.

The graph shows the volume of peat compost and peat-free compost used in gardening from 1999 to 2009.

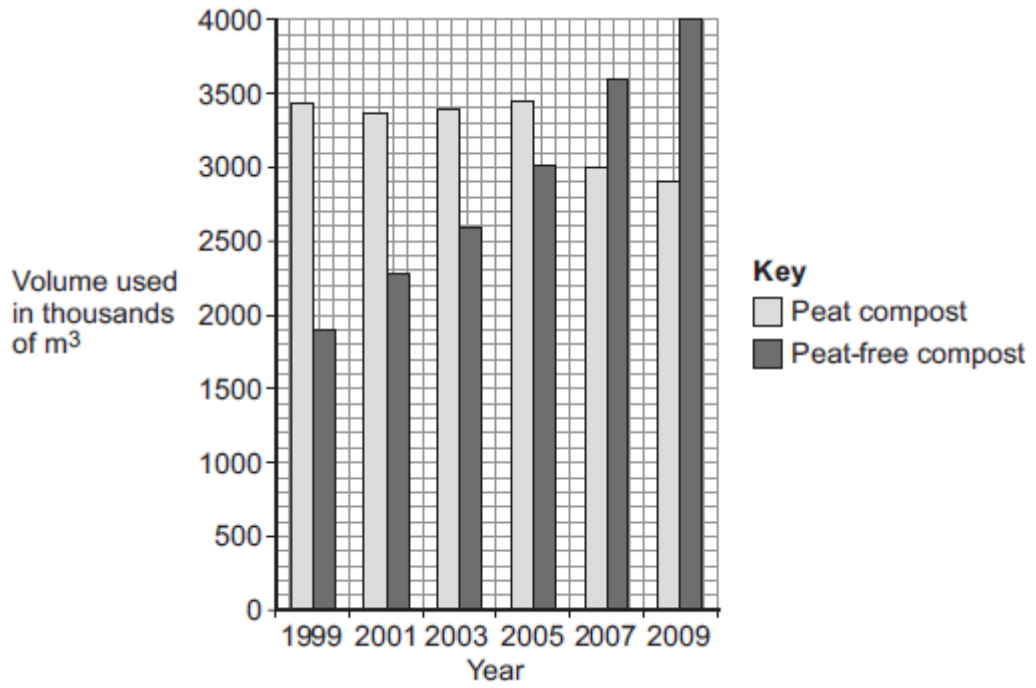

(a) Describe the trends shown in the graph.

(2)

(b) What effect does the destruction of peat bogs have on the gases in the atmosphere?

(1)

(c) Deforestation is also damaging ecosystems.

Describe **one** effect of deforestation on ecosystems.

(1)

(Total 4 marks)

Mark schemes

Q1.

- (a) (placed) randomly
allow description of placement 1
- sufficient number (of quadrats) used 1
- count (dandelions) in each quadrat 1
- use mean number of dandelions, area of quadrat and area of field to estimate population
accept (area of field / area quadrat) × mean number of dandelions per quadrat 1
- (b) $(40 \times 145) / 0.25 = 23\,200$ 1
- $(0.42 \times 23\,200 =) 9744$
allow 9744 with no working shown for 2 marks
allow ecf from correct attempt at the previous step) × 0.42 for 1 mark 1
- (c) **Level 2 (3–4 marks):**
A detailed and coherent explanation is given. Logical links between clearly identified relevant points are made to explain why dandelion growth may be limited.
- Level 1 (1–2 marks):**
Discrete relevant points are made. The logic may be unclear.
- 0 marks:**
No relevant content
- Indicative content**
- factors that may be considered:**
competition for resources including:
- light
 - water
 - space
 - mineral ions (allow nutrients / salts / ions from the soil)
- reference to why growth may be limited:**
- (light) energy for photosynthesis
 - water as a raw material for photosynthesis / support
 - surface area exposed to light
 - sugar / glucose produced in photosynthesis
 - (space) to grow bigger
 - (space) for growth of root system
 - (mineral ions) for growth
 - (mineral ions / sugar) for production of larger molecules **or** named example

4

Q2.

- (a) burning / combustion fossil fuels / burning wood
accept named fossil fuel
accept driving cars / any vehicles
*do **not** accept burning / combustion unqualified*
*do **not** accept factories*
ignore factory chimneys unqualified
ignore respiration 1
- deforestation 1
- (b) (i) (overall) increase 1
- fluctuations
highs are higher and
lows are not as low = 2 marks 1
- (ii) no – could be due to some other factor **or**
could be coincidence **or** fluctuations ±
same size as the overall rise or large
fluctuations or sometimes when CO₂ rises temperature doesn't 1
- (c) any **one** biotic **or** abiotic effect eg:
*do **not** credit just "climate / weather change"*
allow extreme climate / weather change
- changes in rainfall
accept drought, desert formation
- ice-caps melting / rise in sea level
accept flooding
- changed pattern of winds
- changed pattern of migration
- changed species survival
- changed growth 1

[6]

Q3.

- (a) (i) photosynthesis 1
- (ii) respiration
do not credit combustion
do not credit decay 1
- (iii) dry

accept hot **or** windy **or** drought

1

(b) any **three** from

* evaporation (of water)

or loss of water vapour

* (mostly) from the leaf / leaves

do not credit incorrect reference to leaves

* through the stomata

accept through each stoma

accept through the stomas(sic)

* causing a pull

***or** causing an increase in osmotic potential (at the top of the plant)*

***or** causing an increase in water potential (at the top of the plant) **or** causing a decrease in osmotic pressure (at the top of the plant)*

* (so that) water moves up (through the plant)

do not credit water vapour moves up through the plant

* as the transpiration stream

* water enters through roots (and goes up plants)

3

[6]

Q4.

(a) 21 600

no marks for working

1

(b) soil not held in by tree roots

1

water falls on the soil or wind reaches soil

or trees normally intercept

or

soil washed away or soil blown away

1

(c) (i) less carbon dioxide removed

or trees (normal) remove CO₂

ignore reference to O₂

1

more carbon dioxide added by burning
(wood)

or (more) CO₂ from decomposition

1

(carbon dioxide) stops (radiant) heat
escaping from earth

or less heat escapes

1

- (ii) any **two** from:
changed patterns of rainfall **or** wind or causes drought
NOT just 'climate change'
accept increased evaporation

polar ice caps melting **or** sea levels rise
or desert formation **or** loss of habitat

changed plant growth **or** changed distribution of species
or species become extinct
accept named example
accept killing and dying of species

2

- (iii) (more) photosynthesis (because more trees)

1

(more) carbon dioxide removed from
atmosphere **or** trees remove CO₂
*ignore references to transpiration **or** water vapour*
(as a minimum photosynthesis uses CO₂ = 2 marks)
ignore reference to oxygen

1

[10]

Q5.

- (a) (i) to go under teeth **or** mower
accept not damaged by grazing animals
accept do not get cut or bitten
accept reduces competition by other plants
do not credit maximum surface of leaves facing Sun

1

- (ii) any **one** from

it can force its way through grass roots
accept in competition with grass roots

it is a store of food (to help the plant
recover)
do not credit a good store of water

to reach down to water

to give good anchorage
accept it is hard to pull up

1

- (iii) any **one** from

to reach more light
*accept to get out of the shadow of the
hedge **or** tall grass*

to let seeds be caught on animals' coats
(more easily)

*accept improves access **or** visibility **or** ease for pollination
do not credit to help it grow up the hedge*

1

(iv) any one from

(they reach out from hedge) to find
water

*accept increase surface area
accept to find nutrients **or** minerals
do not award mark if food mentioned*

to give good anchorage

1

(b) (i) gene **or** allele

do not credit chromosome

1

(ii) any **one** from

they do not crossbreed **or** interbreed

*accept different species do not breed together **or** do not
fertilise each other*

do not produce fertile offspring

have different numbers or types of chromosomes

*accept genes are incompatible
do not credit have different genes **or** are genetically different
do not credit do not pollinate each other*

1

(c) one mark is for the adaptation and one
is for an appropriate reason

have white fur

for camouflage

are huge

for large volume to surface area

thick layer of fat

*for insulation or to reduce heat loss **or** retain heat
do not credit to stop it losing heat **or** withstand the cold **or**
keep it warm*

have thick fur

*for insulation **or** to reduce heat loss **or** retain heat*

hibernate

to avoid the coldest part of year

is a carnivore

because animals provide high energy food

has big paws **or** claws
to be able to walk on snow

have small ears
to reduce heat loss

have furry feet
for insulation from the snow

2

[8]

Q6.

(a) any **two** from

- deforestation reduces carbon dioxide removal from the atmosphere
accept less photosynthesis for reduces carbon dioxide removal
accept cutting down trees for deforestation
ignore cutting down plants
accept there are less trees to remove carbon dioxide
- burning wood / trees (releases carbon dioxide)
- microbes decay / decompose wood / trees (releasing carbon dioxide)

2

(b) may cause a rise in sea level

accept may cause polar / ice caps to melt / flooding
*do **not** accept global warming **or** greenhouse effect **or** erosion*

1

may cause changes in the Earth's climate

*accept causes changes in the weather **or** named, comparative **type** of weather **or** drought*
accept seasonal changes

1

(c) methane

*accept natural gas **or** CH₄*

1

[5]

Q7.

(a) any two from:

agriculture

*accept land to grow crops **or** graze cattle*

buildings

roads

any 2 different uses for wood for 1

- mark each
- accept wood for burning (energy)*
accept timber for wood 2
- (b) (i) (USA has) more wealth / technology /
devices / need for electricity 1
- (ii) damage done
e.g. pollutant / mining / non-renewable / deforestation 1
- linked effect
*e.g. greenhouse effect / visual pollution / run out of
resources / flooding* 1
- (c) (i) **Problem** – because some people did not want to pay the (landfill) tax 1
- Waste dumped elsewhere 1
- (ii) named example of
- Reduce** – such as less packaging / repairing 1
- Reuse** – such as glass bottles / shopping bags / ink jet cartridges 1
- Recycle** – such as metals, glass, paper
Mark as a whole 1

[10]

Q8.

Quality of Written Communication

1 mark for correct sequencing
burning → named gas → correct
environmental problem

1

any **three** from:

coal / fossil fuel is burned

(water vapour and carbon dioxide and) sulphur dioxide formed
accept nitrogen oxides

(gases) dissolve / react in rain
accept dissolve / react in water vapour

make acid rain

damages trees
accept harms plants or animals or damage to buildings

makes rivers /lakes acidic

accept carbon dioxide is a greenhouse gas / causes global warming for 2 marks

3

[4]

Q9.

(a) 1 for insulation / prevents heat loss

keeps cold out neutral keeps it warm neutral

1

2 camouflage / other animals cannot see it

1

(b) 1 heat loss

reject shade

1

2 insulation from hot sand / prevents heat passing from sand / prevents burning

1

[4]

Q10.

Quality of written communication: One mark for using correct scientific terms microorganisms and respiration

1

(air contains) oxygen

1

(microorganisms break down human waste) by respiration (which releases carbon dioxide)

1

[3]

Q11.

any **two** from

swollen stem stores water (for dry periods)

reduced leaves / spines lose less water /less transpiration / less evaporation

idea of long roots absorb water from deeper / more spread out in soil

[2]

Q12.

(a) increases in human population;

gains 1 mark

2 of:

have led to need for land to be used for housing;

and for industry; farming; transport; leisure

each for 1 mark

3

- (b) 4 of e.g.
 reduced number of habitats;
 possible reduction in number of species;
 more waste/pollution;
 examples of pollution;
 one effect of this waste;
 reference to herbicides/pesticides;
 references to excess fertilisers;
 reference to food chain effects

each for 1 mark

4

[7]

Q13.

- (i) fewer hedges
 marsh drained
 less woodland/trees
 more farm buildings

any 2 for 1 mark each

2

- (ii) fewer
 e.g. fewer habitats

for 1 mark each

2

[4]

Q14.

- (a) fuels
 smoke / sulphur dioxide
 smoke / sulphur dioxide
 pesticide / fertiliser
 pesticide / fertiliser

for 1 mark each

5

- (b) produces acid (rain)

for 1 mark

which may damage trees (*reject* plants unqualified)
 which may make lakes / rivers too acid for animals or plants
 which may affect stonework / metals / paint
 (*ozone damage or global warming disqualifies the effect mark*)

any one for 1 mark

2

[7]

Q15.

- (a) long / pointed horns **and** for defence
 long legs **and** to run away *reject strong / powerful legs*
 long legs **and** to kick predator
 tall **and** can see predators a long distance away but accept
 eyes on side of head **and** to see predator approaching
 large ears **and** to hear predators approaching
 pattern **and** for camouflage any

- two for 1 mark each*
- 2
- (b) (i) fall in morning / day and rise at night or any reasonable
for 1 mark
description of whole pattern for one mark
- 1
- (ii) loss due to evaporation or transpiration in day / absorbed from air
at night / when cool
for 1 mark
- 1
- (c) (i) 19.30 – 20.30 **and** 07.30 – 08:30
for 1 mark
- 1
- (ii) highest moisture content in grass
needs water in desert conditions / response to shortage of drinking water
sensible reference to less chance of predation
any two for 1 mark each
- 2

[7]

Q16.

- (a) from 20.00 to 4.00
for 1 mark
- 1
- (b) line correct length
for 1 mark
- 1
- (c) e.g. it is dark so fewer predators can see it,
for 1 mark each
- 2

[4]

Q17.

- (a) 1 mark for each correct set of plots
for 1 mark each
- 2
- (b) (i) number of voles/amount of food
for 1 mark
- 1
- (ii) e.g. increased number of owls
new disease
for 1 mark each
- 2

[5]

Q18.

- (a) glucose/sugar water

for 1 mark each

- (b) (i) 204
for 1 mark 2
- (ii) 49 **gains 2 marks**
(incorrect answer, but correct method gains 1) 1
- (iii) 3 **gains 2 marks**
(incorrect answer, but correct method gains 1) 2

[7]

Q19.

- (a) 2 of e.g.
competition for food competition for space disease 2
- (b) e.g.
greys eat greater range of food
greys larger – more effective competitors 2

[4]

Q20.

- (a) it has a long/thin beak;
which enables it to reach down the long flower tube/OWTTE;
(allow qualified answers in terms of wings)
(allow two adaptations) 2
- (b) it has a sharp beak;
which enables it to peck through the base of the flower tube/OWTTE
(allow qualified answers in terms of feet)
(allow two adaptations)
each for 1 mark 2

[4]

Q21.

- (a) wolves 1
- (b) moose and wolves are on different scales 1
- (c) wolf population has increased so more moose are eaten
do **not** accept there are more wolves than moose 1
- (d) any **two** from:
- (other) predators

allow correct examples
allow 'humans hunting moose'

- (new) pathogens
allow diseases
- competition

2

(e) any **four** from:

- variation (within species) of antler size
allow description relating to antlers
- (caused by) different genes
- as a result of sexual reproduction / process of meiosis / mutation
- (phenotype) most suited to environment most likely to survive and breed
ignore natural selection unqualified
- genes for large antlers (more likely to be) passed on to next generation

4

reference to mate selection

or

fighting

or

gaining territory

or

competition for mates

or

avoiding predation

1

[10]

Q22.

(a) 1 mark for each

respiration

eaten

decay

burning

4

(b) (i) digests **or** breaks down **or** decays
dead (organic) material

accept rots for digests

accept plants for dead organic material

*do **not** accept 'live on' **or** 'decompose'*

1

(ii) bacteria **or** worms **or** maggots

*accept microbes but **not** germs **or** viruses*

1

[6]

Q23.

(a) (i) 144

1

- (ii) 1955 **or** 1979 1
- (b) (i) $144 - 12 = 132$
allow 130, 134
allow a transfer error from part (a) 1
- (ii) disease **or** predators **or** sterility **or**
starvation **or** migration **or** climatic **or**
weather change
*award **one** mark for an awareness that any of the following
factors could reduce the rabbit population*
*accept words to the effect of e.g vegetation decreased =
starvation*
e.g. humans named as predators
*do **not** accept gender bias of offspring **or** 'too crowded'
unless qualified* 1
- (c) there's only enough food **or** water **or**
space for about 140
*do **not** accept statements equating births and deaths or
increase or decrease in predators* 1

[5]

Q24.

- (a) burning fossil fuels / named example
*accept driving cars / lorries etc burning fuels in power
stations*
ignore combustion unqualified
*do **not** accept catalytic converter on its own **or** emissions
from power stations* 1
- (b) (i) pollutants / smoke breathed in 1
- (ii) SO₂ and deaths rise (and fall) at same times **or**
SO₂ and deaths parallel each other / show same pattern 1
- (iii) no – could be due to some other factor / pollutant /
to smoke **or** correlation not precise / described
explanations must come to a conclusion
named examples must be plausible allow 'coincidence' 1

[4]

Q25.

- (a) any **two** from:
ignore CO₂ release unqualified
- burning
 - activity of microbes / microbial respiration

- less photosynthesis
do **not** accept CO₂ taken in for respiration
 - or**
 - trees take in CO₂
 - or**
 - less CO₂ locked up in wood
 - CO₂ given off by clearing machinery 2
- (b) (i) range of different species 1
accept idea of variety of organisms or plants or animals
- (ii) any **one** from:
- organisms may produce substances useful to humans
do not accept if food is only example
 - duty to preserve for future generations
 - effect on other organisms e.g. food chain effects
ignore effect on human food supply
 - loss of environmental indicators 1

[4]

Q26.

- (a) (i) 20 1
- (ii) 12000 1
- (b) area of strips
- or**
- length / width / size of transect
- or**
- number of transects 1
- (c) (i) since squirrels mobile
- or**
- squirrels could be counted twice
- or**
- squirrels hide

(ii) any **two** from:

- numbers of larders observed likely to be lower than actual
*do not accept squirrels share larders
or squirrels have more than one larder*
- since unlikely that all could be spotted if 5 m away
- old larder
- squirrels moved on / died
- young squirrels
- haven't made a larder

2

(d) (i) 0 to 6.8

1

(ii) any **one** from:

do not accept squirrels prefer blue spruce

- squirrels prefer blue spruce cones / seeds / nuts as food
- more cones / food
- more nesting sites
- fewer predators / competitors

1

[8]

Q27.

adaptation and linked advantage eg

max 2 for 3 adaptations

2

- roots widespread / long (1)
to collect water from large area (1)
*ignore large roots
accept to collect more water*
- some roots deep / long (1)
to collect water from deep down (1)
*ignore large roots
accept to collect more water*
- absence of leaves(1)
reduces water loss (1)
- swollen stem (1)

to store water (1)

- roots near surface (1)

to absorb rainwater (1)

- roots widespread (1)

support in sandy soil (1)

2

[4]

Q28.

(a) 1 mark for each adaptation and 1 mark for its correct linked advantage

- long / thick hair / fur (1)
for insulation (1)
allow keeps warm
- small ears (1)
for reduced heat loss (1)
- small feet (1)
for reduced heat loss (1)
ignore wide feet
ignore prevent sinking
- white fur / coat (1)
for camouflage / poor emitter (1)
- small SA/V ratio (1)
reduces heat loss (1)
- thick layer of fat (1)
insulates / keeps warm (1)

max 4

(b) 1 mark for each adaptation and 1 mark for its correct linked advantage

- horns (1)
for defence (1)
- long legs (1)
for speed / escape / vision (1)
- light colour (1)
for camouflage (1)
allow pattern
- eyes on side of head (1)
for wider field of vision (1)
- hooves (1)
for speed / escape (1)
- large ears (1)
to hear predators better (1)

max 4

[8]

Q29.

(a) 3.2

award **both** marks for correct answer irrespective of working
if answer incorrect

$$(55 + 55 + 1.2 + 5) - (110 + 3)$$

or

$$116.2 - 113$$

or

$$(55 + 55 + 1.2 + 5 + 90) - (110 + 93) \text{ gains 1 mark}$$

2

(b) any **one** from:

- less carbon dioxide taken in by trees
ignore carbon dioxide released by trees or trees store carbon dioxide
- less photosynthesis
- burning trees releases carbon dioxide
- decay releases carbon dioxide

1

[3]

Q30.

(a) streamlined / aerodynamic / swept-back / arrow-shaped / dart-shaped wings / tail

allow pointed / curved wings

ignore pointed tail / beak

OR

large / long wings

ignore large tail

1

(b) no / fewer insects / food (in winter)

*allow **too** cold*

ignore not adapted to cold

ignore day length

1

(c) (i) any **two** from

- feed / hunt at different heights **or** swifts feed higher up
- feed / hunt at different times **or** swifts feed at night
- arrive / depart at different times

2

(ii) nesting sites / territory / habitat

allow homes / space

ignore food unqualified

allow well qualified food answers

eg insects / food near the ground

or

insects / food when it's light

or

insects / food between early May and early August

1

[5]

Q31.

(a) B and D

both required in any order

1

(b) any **two** from:

*do **not** accept compounds restricted to animals*

- carbohydrate / named example
allow 2 marks for 2 named examples
*do **not** allow a general name and a named example for 2 marks (eg award 1 mark only for carbohydrate and starch)*
- protein / enzyme
allow 2 marks for 2 named examples
- amino acid
- hormone / named plant hormone
- lipid / fat / oil / wax
- chlorophyll
- DNA
- vitamin(s)

2

(c) contains minerals / salts / ions / nutrients / named

ignore 'food'

*do **not** allow vitamins / glucose / energy etc*

1

(needed by plants) for health / better growth

for / help plant growth is insufficient

ignore moisture retention / soil structure

ignore more plants

allow examples linked to mineral eg contains magnesium to make chlorophyll for 2 marks

1

[5]

Q32.

(a) 5

1

(b) any **one** from:

allow in either section

- more light
allow more sun / sunnier
- warm(er) / hot
- more water / lot of rain

1

increased / more photosynthesis

allow in either section

allow more biomass / carbohydrate / named (made)

*do **not** allow food*

allow enzymes / metabolism faster

NB for 2 marks this must be linked to heat

to gain 2 marks more / increased must be mentioned at least once

1

(c) less pollution / named pollutant eg carbon dioxide / ☐fumes☐ / emissions

allow examples of effect of less pollution

eg less global warming / less acid rain

allow any relevant environmental effect

eg imported diseases

1

less fuel used / less transport / named transport

ignore 'less distance' / importing

allow 'less distance travelled' / 'less travel'

allow smaller carbon footprint once only for either mark

1

[5]

Q33.

(a) any **two** from:

- streamlined / smooth
allow description eg long and thin ignore slimy / oily skin unless qualified
- flippers
*allow fins **or** webbed feet*
- flattened / long / large / powerful tail
tail must be qualified to gain credit

2

(b) **1** mark for each adaptation and **1** mark for its correct linked advantage

correct advantage mark can be awarded if adaptation is attempted but not awarded the mark

eg

fat / blubber (1)

ignore skin / fur

insulates (1)

allow keeps warm

or

large mass to area ratio **or** small area to mass ratio (1)

ignore large body unqualified

allow volume for mass

heat loss reduced (1)

ignore keeps warm

2

[4]

Q34.

(a) (i) increased water uptake

ignore nutrients / food

allow quicker water uptake

allow collects water over larger area

1

(after) rain

accept ideas in terms of more successful competitor

1

(ii) water storage **or** stability **or** safety from predators

ignore absorption of water from soil

1

(b) reduces water loss / evaporation

accept reduces transpiration

allow stops water loss

1

wax protects plant **or** reflects heat **or** keeps plant cool **or** unpalatable

ignore reflects light

1

folding reduces surface area **or** folding reduces warming

*accept enclosed stomata **or** less exposure of stomata **or** increased humidity **or** less water concentration gradient*

allow prevents burning

ignore less likely to be damaged

1

[6]

Q35.

(a) (i) quadrat / grid

allow suitable description in a(i) or a(ii)

allow quadrat

1

(ii) any **two** from:

- use a transect / description
allow measure distance of the test or sample site from road
- sample every metre
ignore random placing of quadrat
- count plants (in quadrat)

2

(iii) the nearer to the road, the more (plantain) plants

accept the more dead nettles the less plantains

1

(b) (i) any **two** factors from: eg

- grow better / survive away from road
- sensitive to pollutant / named pollutant / dust / fumes
ignore carbon dioxide as pollutant
- (roadside) weedkillers
- trampling / damage / turbulence
- grass cutting
- competition
- aspect eg hillier

or

give **one** mark for a factor and **one** mark for its effect eg

dust (from road) (1)

reduces photosynthesis (1)

or

'loses' in competition (1)

for light / water / nutrients / minerals / ions / space / soil (1)

ignore food for plants

2

(ii) any **two** factors eg

ignore distribution

- can withstand pollution
allow grows better in polluted air
ignore 'prefer' pollution
- competition

- aspect eg flat

or

give **one** mark for a factor and

one mark for its effect eg

use carbon dioxide (from traffic) (1)

enhances photosynthesis (1)

or

'wins' in competition (1)

ignore food for plants

for light / water / nutrients / minerals / ions / space (1)

2

[8]

Q36.

(a) any **two** from:

- shorter distance between samples
ignore repeat investigation / measurements
- sample to greater height
- specify the size of each site
ignore longer transect

1

(b) (i) Parmelia

1

(ii) Evernia

1

(c) any **two** from:

- Lecanora does not extend over whole range of transect / does not grow everywhere / does not grow in town centre / does not grow in countryside
- Lecanora grows in a range of sulfur dioxide concentrations **or** Lecanora only grows in limited range of sulfur dioxide concentrations **or** Lecanora lives over large range of sulfur dioxide concentrations
- other factors eg different pollutant might also influence growth of Lecanora
- sulfur dioxide / pollutant concentration was not measured
ignore Lecanora does not give accurate measure of sulfur dioxide concentration
- amount of Lecanora not measured

2

[5]

Q37.

1 mark for each adaptation and 1 mark for its correct **linked** advantage

fur / long hair / thick coat (1)

for insulation / reduces heat loss (1)

allow keeps warm for insulation point

large body / large mass / small (1) SA:V ratio

ignore layer of fat

retains heat / loses less heat (1)

ignore keeps warm

short legs (1)

reject short (height) / small (height)

reduces surface area / heat loss (1)

ignore keeps warm for this point

small ears (1)

reduces surface area / heat loss (1)

ignore keeps warm for this point

horns (1)

defence (1)

large shoulders (1)

to move through snow (1)

[4]

Q38.

(a) any **two** from:

- food / feeding

ignore water

- mates / mating

- territory / space / land / shelter / nesting sites

ignore homes / place to live / habitat / resources

- status (within group)

2

(b) (i) rises to 1480 to 1500
or rises by 880 to 900
or rises until 1993

ignore incorrect figures if 1993 given

1

falls to 400 to 440 **or** falls by 1040 to 1100

*if neither mark gained then allow 1 mark for rise followed by fall **or** fell by 160 to 200*

1

- (ii) rises because: -
 less competition from mule deer
or mule deer population falling
or fewer mule deer
ignore reference to food / breeding
ignore reference to predation / disease

1

- falls because: -
 more competition from mule deer
or mule deer population rising
or more mule deer
ignore more / less suited to environment
if neither mark gained then correct reference to competition
gains 1 mark

1

[6]

Q39.

- (a) any **two** from:

ignore size of dish

- colour of dish **or** all dishes black
- (same) amount of each seed
- position of dishes **or** all dishes in same place / garden
ignore wood
- time observed / visited / left

2

- (b) sunflower

1

- (c) (i) (No)

named seed does not fit pattern

or

millet / safflower / corn eaten a lot but have little fat

or

the seed with the highest percentage eaten has least fat

accept converse

1

- (ii) *allow separate references to sunflower and niger*

table 1 mark

- highest number of visitors **or** large range of visitors
allow most popular

1

table 2 mark

- high percentage eaten

or

contain high fat for energy / insulation

allow most eaten

1

[6]

Q40.

- (a) (i) (white) clover

1

- (ii) reed sweet-grass

allow reed

allow grass

1

- (iii) (only) found in swamp and aquatic zones **or** only found in water
or doesn't grow in marsh

ignore wet conditions

1

- (b) Marks awarded for this answer will be determined by the Quality of Written Communication (QWC) as well as the standard of the scientific response. Examiners should also apply a 'best-fit' approach to the marking.

0 marks

No relevant content.

Level 1 (1-2 marks)

There is a basic description which describes how a quadrat **or** a metre tape could be used to collect data

Level 2 (3-4 marks)

There is a clear description of how a quadrat **and** a metre tape could be used to collect data along a line

Level 3 (5-6 marks)

There is a clear, logical and detailed description of a method that will produce valid, repeatable results across / at intervals along the stream.

examples of procedural points made in the response:

- use of tape measure to produce transect
- placing of quadrats
- transect placed across stream
- score presence of each plant species
- use quadrat at regular intervals along tape
- repeat transect several times (≥ 3)

- along stream
- at random **or** regular intervals

6

[9]

Q41.

there are no / few predators of the lionfish
or spines protect lionfish from predation

allow warning colouration / poisonous

or no / fewer disease organisms

1

predators / prey in Atlantic do not recognise lionfish
or not fished by humans

allow high reproduction

1

also there is abundant food in Atlantic
or there is no / less competition in Atlantic

ignore adaptation to new environment

1

[3]

Q42.

Marks awarded for this answer will be determined by the Quality of Written Communication (QWC) as well as the standard of the scientific response. Examiners should also apply a 'best-fit' approach to the marking.

0 marks

No relevant content.

Level 1 (1-2 marks)

There is at least one example of an adaptation of either an animal **or** a plant. However it may not be clear how the adaptation helps the organism to avoid being eaten.

Level 2 (3-4 marks)

There is a description of an adaptation of at least one animal **and** at least one plant. It is clear how at least one of these adaptations helps the organism to avoid being eaten.

Level 3 (5-6 marks)

There are clear and detailed descriptions of a range of adaptations of named animals **and** named plants. It is clear how most of these adaptations help the organisms to avoid being eaten.

examples of clear and detailed biology points made in response:

- **camouflage** – the method of camouflage should be described plus a statement that the predator is less likely to see the prey
- **mimicry / warning colouration** – the method should be described plus a statement that the predator is likely to confuse the prey with e.g. a poisonous organism
- **thorns / prickles / spines / horns** – a statement that these are sharp and are likely to hurt a predator

- **long limbs / streamlining** – a statement that these increase speed and make it more likely that prey will outrun predator
- **bad taste / poison** – a statement that predator will find this unpleasant and ‘spit out’ prey / not attack same prey again
- **large ears / position of eyes** – a statement that predators will be detected earlier so the prey can escape sooner

[6]

Q43.

- (a) (soft) body parts / other parts / named parts

accept flesh

1

decayed / decomposed / rotted / eaten

or

bones do not decay / decompose / rot / get eaten

ignore disintegrated / dissolved

ignore microorganisms

1

- (b) any **one** aquatic feature from: eg

- streamlined body shape
- long tail
- eyes on top of head
- scales
- fins / paddles / flippers / webbed feet

ignore gills

1

any **one** terrestrial feature from:

- (front) legs / limbs / hands
- could lift front end upwards

ignore feet

accept for 2 marks eg fin / flipper can be used for walking

or fins like legs

1

[4]

Q44.

- (a) (reduced) competition

ignore fighting

1

for any **one** from:

- light

ignore Sun

- water
- nutrients / ions / salts / minerals
ignore food
- space
allow less overcrowding
- colonise new areas

1

(b) hooks

allow spines

1

attach to animals / human clothing / animals carry fruits long distances

ignore wind dispersal

1

[4]

Q45.

(a) any **three** from:

- streamlined shape enables it to swim quickly (to catch fish)
- wings (provide power) to move quickly (to catch fish)
allow 'flippers'
- wings used for steering
- white underside / dark top acts as camouflage (so prey less likely to see it)
- long / sharp beak to catch fish

3

(b) any **three** from:

- reduces (total) surface area of penguins exposed to wind / cold atmosphere
- reduced number of penguins exposed (to wind / cold)
accept reference to movement in or out of the huddle
accept outer ones insulate / act as barrier
- reducing heat loss
allow reduced cooling
- 'share' body warmth / heat

3

(c) (i) any **two** from:

- size of tubes
- volume of (hot) water
accept amount of (hot) water
- left for same length of time
allow measured at same time intervals
- starting temperature

2

(ii) any **two** from:

- tube alone (**C**) lost heat most (rapidly)

- tube **B** intermediate
 - tube **A** least (rapidly)
- allow correct use of figures for all 3 tubes*
ignore just quoting final temperature

2

(iii) confirms suggestion

no mark awarded

accept correct answers referring to other suggestions in (b)

since (both outer and inner) tubes in bundle lost heat less rapidly (than 'stand – alone' tube)

comparison needed

1

penguins in a huddle lose less heat (than single ones)

accept 'it is the same for penguins'

1

(d) **if the core body temperature is too high**

blood vessels supplying the skin (capillaries) dilate / widen

*accept reference to arteries / arterioles but **not** veins / capillaries*

*do **not** accept references to movement of blood vessels*

ignore enlarge / expand

reference to skin / surface required only once

1

so that more blood flows through the (capillaries) in skin / near surface

reference to 'more' needed at least once to gain 2 marks

1

and more heat is lost

reference to 'more' needed at least once to gain 2 marks

1

if the core body temperature is too low

blood vessels supplying the skin (capillaries) constrict / narrow

allow full marks if 'too low' given first

if no other marks awarded, allow vasodilation when too warm

***and** vasoconstriction when too cold for 1 mark*

1

(e) (i) wings move to provide movement for diving

allow muscles contract / work

1

energy (for movement) comes from respiration

*do **not** allow produces / makes / creates energy*

allow energy comes from / is supplied by / is released by respiration

1

respiration / muscle contraction also releases heat

allow produces heat

1

(ii) any **three** from:

- feet not / less used **or** no muscle contraction in feet
allow little energy / heat released through respiration in feet
*do **not** allow veins / capillaries*
- vessels supplying feet constrict / less blood to feet
- so temperature in feet cools / decreases
- more heat loss from large surface area or rapid flow of cold water over foot

3

[22]

Q46.

Marks awarded for this answer will be determined by the Quality of Written Communication (QWC) as well as the standard of the scientific response. Examiners should also refer to the information in the [Marking guidance](#).

0 marks

No relevant content.

Level 1 (1-2 marks)

For at least one process **either** the organism that carries it out **or** the carbon compound used **or** the carbon compound produced is described **or** for at least one organism **either** the carbon compound it uses **or** the carbon compound it produces is described **or** at least one process is named

Level 2 (3-4 marks)

For some processes (at least one of which is named) **either** the organisms involved **or** the carbon compounds used **or** the carbon compounds produced are described

Level 3 (5-6 marks)

For at least one named process an organism **and** either the carbon compound used for the process **or** the carbon compound produced by the process are described **and** for other processes (at least one of which is named) **either** the organism **or** the carbon compounds used **or** the carbon compounds produced are described (as in Level 2)

Examples of Biology points made in the response:

- (green) plants photosynthesise
- photosynthesis takes in carbon dioxide
- (green) plants use carbon to make carbohydrate / protein / fat / organic compounds / named (e.g. enzymes / cellulose)
- animals eat (green) plants (and other animals)
- (green) plants respire
- animals respire
- respiration releases carbon dioxide
- (green) plants and animals die
- microorganisms decay / decompose / rot / break down / feed on dead organisms
- microorganisms respire

Q47.

- (a) estimate / count number of squares covered
do not allow number of squares containing algae 1
- divide by total number of squares and multiply by 100 / multiply by 4 1
- (b) (i) any **two** from:
- more / most in North east facing
 - followed by the North facing
 - the South facing had no green alga / least
- 2
- (ii) 40 (%) 1
- two directions had this value (rest of directions had only one)
accept this is the most common percentage / value
2nd mark only if 40(%) 1
- (iii) any **three** from:
- light / sunlight
ignore Sun / carbon dioxide
 - temperature
do not accept oxygen
 - availability of water / humidity
 - availability of nutrients
 - wind
 - pollution qualified eg SO₂, acid rain, soot
 - grazing by animals eg slugs
 - competition with other species
 - pH
- 3
- (iv) eg (*for light*)
allow overlap between factors
- light intensity *least* on north / north east facing parts of tree (1) 1
- green algae adapted for photosynthesis in low light intensities (1)
allow, since less light from Sun, cooler so less evaporation 1
- negative effect of high light intensity on green algal chlorophyll / photosynthetic pigments (1)
allow green algae unable to withstand desiccation 1
- or** (*for temperature*)
- temperature highest on south (and west) facing parts of tree
 (causing) more water to evaporate from this side of tree

green algae unable to withstand desiccation

or (*for moisture / rainfall*)

rainfall highest on north / north east facing parts of tree (1)

(giving) more moisture on this part of tree (1)

green algae less likely to desiccate (1)

or (*for wind*)

wind speed / duration greatest on south (and west) facing parts of tree (1)

(causing) more water to evaporate from this side of tree (1)

allow wind carries pollutants

allow pollutants toxic to algae

green algae unable to withstand desiccation (1)

or (*from pollution*)

from south / south west (1)

wind carries pollutants (1)

pollutants toxic to / kill algae (1)

- (c) (i) as the concentration of ammonia increases so does the % abundance of nitrophyte lichens

allow positive correlation / proportional

allow directly proportional

1

scattered results / wide spread

allow use of approximate numbers to demonstrate scattering

or

for any value of one parameter there is a wide range of the other

allow not a strong relationship / correlation

1

- (ii) not very useful / unreliable

accept only gives a rough idea / only a general indication

1

for any value of one parameter there is a wide range of the other

allow correlation rather than direct relationship

or

scattered results

1

[16]

- (a) any correct named physical environmental condition, e.g. light / water / rain / temperature / minerals / nutrients / space (between plants)
ignore carbon dioxide / climate / weather / sun / pollution 1
- genes / inheritance
ignore 'variety'
- OR
- any correct named biotic factor e.g. predation / disease 1
- (b) mass of crop also depends on number of pods (per plant) / size / mass of each pea
ignore number of plants 1
- (c) microorganisms / bacteria / fungi / decomposers / detritus feeders / named 1
- decompose / rot / break down / decay / digest
ignore feed / eat 1
- (these organisms) respire
do not allow respiration by pea (plants) 1
- (decay / respiration / microorganisms etc) releases carbon dioxide
do not allow combustion / fossilisation 1

[7]

Q49.

- (a) 1 mark for each adaptation and 1 mark for its correct linked advantage
- long / thick hair / fur (1) for insulation (1)
allow keeps warm
 - small ears (1) for reduced heat loss (1)
 - small feet (1) for reduced heat loss (1)
ignore wide feet
ignore prevent sinking
 - white fur / coat (1) for camouflage / poor emitter (1)
 - small SA/V ratio (1) reduces heat loss (1)
 - thick layer of fat (1) insulates / keeps warm (1)
- (b) 1 mark for an adaptation and 1 mark for its correct linked advantage
- horns (1) for defence (1)
 - long legs (1) for speed / escape / vision (1)

Max 4

- light colour (1) for camouflage (1)
allow pattern
- eyes on side of head (1) for wider field of vision (1)
- hooves (1) for speed / escape (1)
- large ears (1) to hear predators better (1)

Max 2

[6]

Q50.

(a) any **two** from:

ignore CO₂ release unqualified

- burning
- activity of microbes / microbial respiration
- less photosynthesis

or

trees take in CO₂

*do **not** accept CO₂ taken in for respiration*

or

less CO₂ locked up in wood

- CO₂ given off by clearing machinery

2

(b) (i) range of different species

accept idea of variety of organisms or plants or animals

1

(ii) any **two** from:

- organisms may produce substances useful to humans
*do **not** accept if food is only example*
- duty to preserve for future generations
- effect on other organisms, eg food chain effects
ignore effect on human food supply
- loss of environmental indicators

2

[5]

Q51.

Marks awarded for this answer will be determined by the Quality of Written Communication (QWC) as well as the standard of the scientific response. Examiners should also apply a 'best-fit' approach to the marking.

0 marks

No relevant content

Level 1 (1 – 2 marks)

There is at least one reason for deforestation

or

an attempt at a description of at least one way deforestation is affecting the atmosphere.

Level 2 (3 – 4 marks)

There is at least one reason for deforestation

and

a description of the way deforestation is affecting one gas in the atmosphere

or

the process that causes an effect.

Level 3 (5 – 6 marks)

There are reasons for deforestation

and

a clear description of the way deforestation is affecting one gas in the atmosphere

and

the process that causes this.

examples of the points made in the response

Reasons for deforestation

- timber for construction / furniture / boat building / paper production
- growing plants for biofuels for motor fuel / aviation / lawnmowers
- use of wood as a fuel
- land for building or agriculture to provide food, such as rice fields and cattle ranching

Effects of deforestation

- increase in carbon dioxide in atmosphere
due to burning
due to activities of microbes
less carbon dioxide taken in / locked up (by trees)
less photosynthesis
- increase in methane in atmosphere
due to rice production / cattle

extra information

ignore references to oxygen

accept explanations of the effect of water (vapour)

[6]

Q52.

- (a) (i) variation in masses / more representative / more typical / more reliable / average / mean / reference to anomalies

or

one worm to light to measure change

do not allow more accurate / more precise

ignore fair test / valid / repeatable / reproducible

- 1
- (ii) remove solution / liquid (on outside of worm)
allow 'water' 1
- (iii) variable amounts removed from each worm
ignore reference to length of timing 1
- (iv) equal sizes of worm / more worms (in each group) / wash off all the sand / repeats / use more accurate balance / use smaller concentration intervals
allow reference to improve blotting technique eg blot before / blot more thoroughly 1
- (b) (i) different (starting) masses / sizes / weights (at different concentrations)

allows comparisons / shows pattern / shows trend 1
- (ii) (+)20
correct answer = 2 marks, with or without working
or
$$\frac{7.5 \times 100}{37.5} \quad / \quad \frac{7.5}{37.5} \quad / \quad \frac{(45.0 - 1) \times 100}{37.5}$$

for 1 mark 2
- (c) (i) graph:

points correct
allow ± 1 mm
-1 mark per error
allow ecf from part b(ii) 2
- label on x-axis including units – ie Concentration of salt in arbitrary units 1
- line of best fit = smooth curve / ruled straight line
anomaly (4.0, -52) either plotted and ignored re. line
or *not plotted*
do not allow point to point
allow best fit for ecf from 2bii 1
- (ii) on graph:

ring drawn around point at (4.0, -52)
allow (5.0, -50) if cand. line indicates this 1
- (iii) sensible suggestion – eg used wrong solution / used 5.0% instead of 4.0% / different length of time in solutions / ref to error in blotting / balance not zeroed / error in weighing

allow some lugworms died
allow error in calculation

1

- (d) (i) 2.9 to 3.0 / correct for candidate's graph ± 0.1

1

value of no change in mass / worms in equilibrium with soln / described
allow small(est) mass change

1

- (ii) water loss

1

by osmosis / diffusion

1

from dilute region in the worm to more concentrated solution outside
allow correct description in terms of high to low water
concentration / high to low water potential
salt solution is hypertonic
concentration unqualified = salt concentration

1

[19]

Q53.

- (a) (i) correct bar heights
three correct 2 marks
two correct 1 mark
one or none correct 0 marks
ignore width

2

- (ii) (Stream Y)

has many sludge worms / bloodworms

or

has no mayflies / caddis or few shrimp

allow 1 mark if invertebrate not named but correct
association given

1

which indicate medium or high pollution

1

- (b) (i) suspended solids increase (as a result of sewage overflow)

1

then decrease downstream / return to original levels

1

oxygen levels decrease (after sewage overflow)

1

and then rise again

1

(ii) any **three** from:

- mayflies decrease (to zero) near overflow
accept 'have died out'
- because oxygen is low **or** mayflies have high oxygen demand
- mayflies repopulate / increase as oxygen increases again
- can't be sure if dissolved oxygen or suspended solids is the cause

3

(c) they respire / respiration

aerobic respiration gains 2 marks

1

this requires / uses up the oxygen

1

[13]

Q54.

(a) any **one** from:

- get lots of data
accept more reliable / reproducible
do not accept more accurate
- cheap / free
- unlikely to be biased
- can cover a wide area at the same time / takes less time
- see seasonal variations

1

(b) (i) correct bar heights

1 mark for each correct bar

ignore width of bars

2

(ii) 12 800

(16000 / 100)x80 on its own for 1 mark

2

(iii) goldfinch

1

(c) any **one** from:

- more food available
accept fewer predators
- people feed them
accept less habitat / food in countryside
- more rubbish / waste to eat

1

[7]

Q55.

(a) (i) chloroplast

1

(ii) cell wall

1

- (b) (i) osmosis
accept diffusion 1
- (ii) cell wall (prevents bursting) 1
- (c) (i) carbon dioxide
allow correct formula 1
- glucose
allow sugar / starch 1
- (ii) any **two** from:
 - light sensitive spot detects light
 - tells flagellum to move towards light
 - more light = more photosynthesis
 2
- (d) (cell has) larger SA:volume ratio 1
- short (diffusion) distance
allow correct description 1
- (diffusion) via cell membrane is sufficient / good enough
- or**
- flow of water maintains concentration gradient 1

[11]

Q56.

- (a) (i) counts / 12 1
- $\times 120 \times 80 / \times 9600$
or
 \times area of field 1
- (ii) (more) quadrats / repeats 1
- placed randomly
ignore method of achieving randomness 1
- (b) (i) any **three** from:
 - temperature / warmth / heat
 - water / rain
 - minerals / ions / salts (in soil)*allow nutrients / fertiliser / soil fertility*
ignore food

- pH (of soil)
 - trampling
 - herbivores
 - ignore predators*
 - competition (with other species)
 - pollution qualified e.g. SO₂ / herbicide
 - wind (related to seed dispersal).
 - ignore space / oxygen / CO₂ / soil unqualified*
- 3
- (ii) light needed for photosynthesis 1
- for making food / sugar / etc. 1
- effect on buttercup distribution eg more plants in sunny areas / fewer plants in shady areas 1
- (c) (i) fertiliser / ions / salts cause growth of algae / plants 1
- (algae / plants) block light 1
- (low light) causes algae / plants to die 1
- microorganisms / bacteria feed on / break down / cause decay of organic matter / of dead plants
- do **not** allow germs / viruses* 1
- (aerobic) respiration (by microbes) uses O₂
- do **not** allow anaerobic* 1
- (ii) sewage / toxic chemicals / correct named example eg metals / bleach / disinfectant / detergent etc
- allow suitable named examples eg metals such as Pb / Zn / Cr / oil / SO₂ / acid rain / pesticides / litter*
- ignore chemicals unqualified*
- ignore waste unqualified*
- ignore human waste / domestic waste / industrial waste unqualified* 1
- (d) (i) 2 1
- (ii) more food
- allow other sensible suggestion eg more species colonise from tributary streams after forest* 1
- (iii) number of stonefly species decreases (from **A** to **B** / **B** to **C** / **A** to **C**) as more pollution enters river / less oxygen
- allow fewer species in more polluted water*
- ignore none are found at site C*

Q57.

- (a) photosynthesis 1
- (b) (i) 140 1
- (ii) (10 billion tonnes) more added (to atmosphere) than removed
allow ecf from part (b)(i) 1
- [3]

Q58.

- (a) any **three** from:
- parts of organisms have not decayed
accept in amber / resin
allow bones are preserved
 - conditions needed for decay are absent
accept appropriate examples, eg acidic in bogs / lack of oxygen
 - parts of the organism are replaced by other materials as they decay
accept mineralised
 - or other preserved traces of organisms, eg footprints, burrows and rootlet traces
allow imprint or marking of organism 3
- (b) (i) teeth for biting (prey) 1
must give structure + explanation
- claws to grip (prey) 1
accept sensible uses
- wing / tail for flight to find (prey) 1
- (ii) any **two** from:
- new predators
 - new diseases
 - better competitors
 - catastrophe eg volcanic eruption, meteor
 - changes to environment over geological time
accept climate change
allow change in weather
 - prey dies out **or** lack of food
allow hunted to extinction 2

Q59.

- (a) gets more light (near surface)
allow warmer (near surface)
allow bladders contain (more) carbon dioxide 1

(so) photosynthesises more 1

(because) bladders aid floating (when tide is in)

or

- (so) more biomass / glucose / starch produced
*ref to 'more' needed only once, eg gets more light for photosynthesis gains **two** marks*
if 'more' not given do not award mark on the first occasion 1

- (b) lets angler fish see / attract its prey / mates **or** see predators as it is dark (at 1000m)
or
lets angler fish see / attract prey to get food
or
lets angler fish see / attract mates to reproduce
or
lets angler fish see predators to avoid being eaten
*must be in a correct pair to gain **two** marks* 2

[5]

Q60.

- (a) any **two** from:
• (volume of) peat compost has been steady and then declined **or** volume of peat compost has declined since 2005
allow 2007 instead of 2005
• (volume of) peat-free compost has increased (since 1999)
• (volume of) peat is higher than peat-free until 2005, then peat-free compost is higher (than peat)
allow 2007
• total volume of peat and peat-free compost has increased. 2

(b) increases carbon dioxide (in the atmosphere)
ignore methane 1

- (c) any **one** from:
• reduces biodiversity
• destruction of habitats
• disruption of food chains. 1

[4]